

Surgical manual

ECHOPLAN PRO A

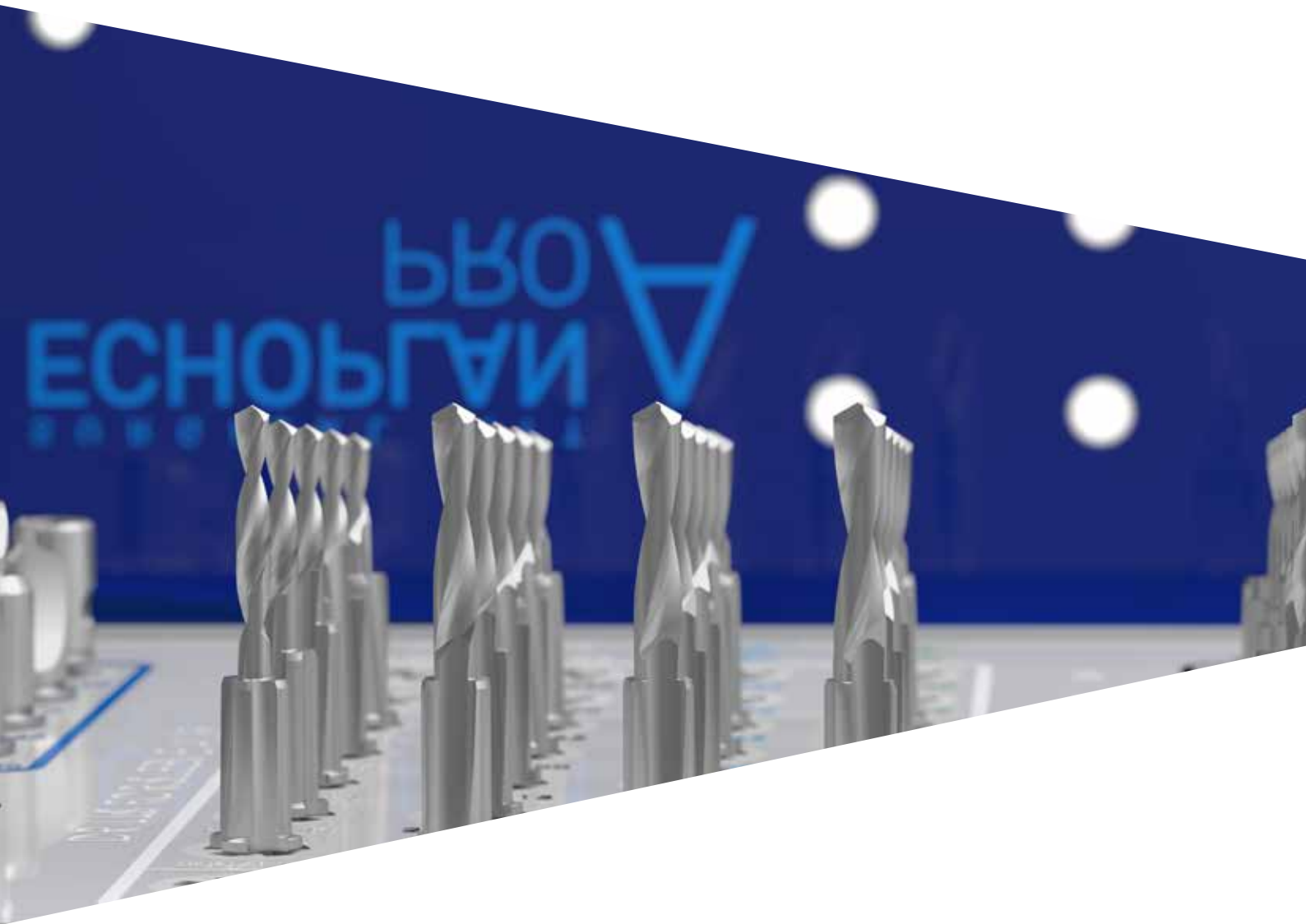

Echoplan PRO A kit



Information

Clinical information about implant-retained prosthetic therapies	4
Side and secondary effects	4
General indication	5
Guide sleeves	6
	8



Premium One and Prama implants

Implant mounters and connections	9
Easy Mounters	9
Premium One implants	10
Prama implants	12
	13



Surgical instruments

General indications	16
Echoplan PRO A surgical kit	16
Rotating instruments	17
Fixing pins and drills	20
From planning to implant insertion: stages in Echoplan guided surgery	21
Surgical instruments used in the initial stage	22
Intermediate and final drills	23
Drills provided with the Echoplan PRO A kit	25
Optional drills for 6.00 and 7.00 mm heights	26
Optional drills for 18.00 mm height	28
Bone taps	28
Countersink drills	30
Drivers for connecting screws	30
Mounters	31
Easy Insert - mounters	34
Hand knob for removal of the GS-MOU-DG mounter	36
GSMOUNT-TRAY-INT mounter organizer	37
A comparison of the control lever TWL and CRI5-KIT	38
	39



Surgical sequences

Preparation of the implant site	42
Surgical sequences – Premises	42
Preliminary surgical sequences	44
Surgical sequences – \varnothing 4.15 mm sleeve	45
Surgical sequences – \varnothing 5.50 mm sleeve	46
Surgical sequences – 18.00 mm height implants	48
	50



Surgical procedures

Insertion of the implant	52
	52

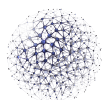

General overview

54

Clinical indications for resorting to implantoprosthesis

When assessing the patient, in addition to his/her eligibility with regards to implant-prosthetic rehabilitation, it is usually necessary to consider the contraindications that apply to oral surgery procedures in general. These include:

- clotting disorders, anticoagulant therapy;
- healing or bone regeneration disorders;
- decompensated diabetes mellitus;
- metabolic or systemic diseases that compromise tissue regeneration with a particular influence on healing and bone regeneration;
- alcohol abuse, smoking and use of drugs;
- immunosuppressive therapy, such as: chemotherapy and radiotherapy;
- infections and inflammations, such as periodontitis and gingivitis;
- poor oral hygiene;
- inadequate motivation;
- occlusion and/or articulation disorders as well as an inadequate interocclusal space;
- inadequate alveolar process.

It is contraindicated to fit implants and implant restorations in patients with poor general or oral health, those who are unable to monitor their general conditions properly or those who have had organ transplants. Psychologically unstable patients, alcohol or drug abusers, and poorly motivated or uncooperative patients should also be considered unsuitable for this kind of treatment. Patients with poor periodontal health should first be treated and allowed to recover. In the presence of a lack of bone substance or poor quality of the receiving bone, such as to compromise the stability of the implant, suitable guided tissue regeneration must be performed prior to implant treatment.

Contraindications also include: bruxism, allergy to titanium (extremely rare), acute or chronic infectious diseases, sub-acute chronic maxillary osteitis, systemic diseases, endocrine disorders, diseases resulting in microvascular disorders, pregnancy, breastfeeding, previous exposure to radiation, haemophilia, neutropenia, steroid use, diabetes mellitus, kidney failure and fibrous dysplasia. The normal contraindications common to all oral surgery must also be observed. Surgery is not recommended for patients on anti-coagulant, anticonvulsant and immunosuppressant therapies, with active inflammatory-infective processes of the oral cavity, and patients with BUN and creatinine values outside the norm. Patients with cardiovascular disease, hypertension, thyroid or parathyroid diseases, malignant tumours found in the 5 years preceding the operation, or nodular swellings must also be rejected.

Chemotherapies reduce or eliminate the ability of osseointegration, therefore patients undergoing these treatments must be carefully screened before being rehabilitated with oral implantoprosthesis. Numerous cases of bisphosphonate-associated periimplant osteonecrosis of the mandible have been reported in the literature. This problem particularly applies to patients treated intravenously.

As a post-operative precaution, the patient must avoid any kind of strenuous physical activity.

Side and secondary effects

Situations that may occur after surgical procedures include temporary local swelling, edema, hematoma, temporary sensitivity alterations, temporary masticatory limitations, post-surgical microhemorrhages in the following 12-24 hours. The patient may also experience pain, speech problems, gingivitis, loss of bone crest, permanent paresthesia, dysesthesia, local or systemic infections, exfoliation, hyperplasia, and oronasal and oroantral fistulas, perforation of the labial or lingual plate, perforation of the Schneiderian membrane, bone fractures, implant fractures, fractures of the overstructures, aesthetic problems, unnoticed perforation of the nasal sinus, nerve injuries, impairment of natural dentition. The following pathophysiological problems can increase the risks: cardiovascular failure, coronary disease, arrhythmia, pulmonary or chronic respiratory disease, gastrointestinal disease, hepatitis, inflammatory bowel disease, chronic kidney failure and disorders of the urinary system, endocrine disorders, diabetes, thyroid diseases, hematologic disorders, anaemia, leukaemia, coagulation problems, osteoporosis or musculoskeletal arthritis, stroke, neurological disorders, mental retardation, paralysis.

Before proceeding, it is important to perform a careful pre-operative analysis of the patient's medical history to verify his or her suitability for the implant treatment. It is also recommended to collect and file all the clinical, radiological and radiographic records.

In addition to both clinical and radiographic oral examination, it is also advisable to conserve the CT of the area affected. Once the radiographic and tomographic documentation has been obtained, the specialist can identify the most suitable implant for the case with the help of reference software.

The pre-operative study of the CT scan allows the identification of the type of bone present in the insertion point of the implant. The choice of the surgical procedure must take into consideration the type of bone present. The bone is normally classified into 4 types according to the density. The classification (according to Carl Misch) is the following:

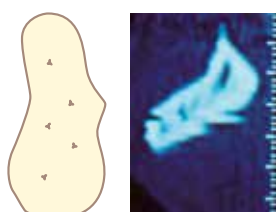

BONE D1: all cortical bone.



BONE D2: a core of bone marrow enclosed in a shell of cortical bone.

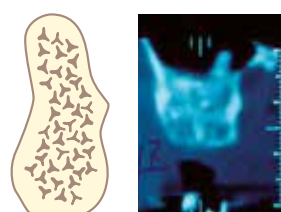

BONE D3: all bone marrow without cortical bone.

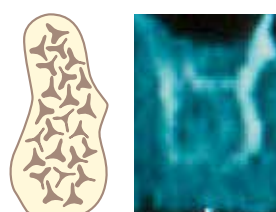

BONE D4: all bone marrow with very poor mineralization.

General indication

The guided surgery implant treatment technique includes diagnosis, planning and positioning. The main advantage is being able to plan the intervention by working with a complete 3D view of the radiological and prosthetic anatomy of patients and so evaluate the dimensions and final position of the dental implant precisely, also in accordance with the prosthetic study (wax-up), and using surgical guides capable of guiding the implant positioning according to this same planning. The Echoplan PRO A surgical kit has been studied and developed for the preparation of surgical sites using the guided surgery with cylindrical implants Premium One and Prama produced by Sweden & Martina. The Echoplan PRO A and the surgical instruments contained in it have been designed so that they are compatible for use with the main guided surgery techniques currently available on the market (three-dimensional diagnostic software and surgical guides). Sweden & Martina has an up-to-date list available upon request.

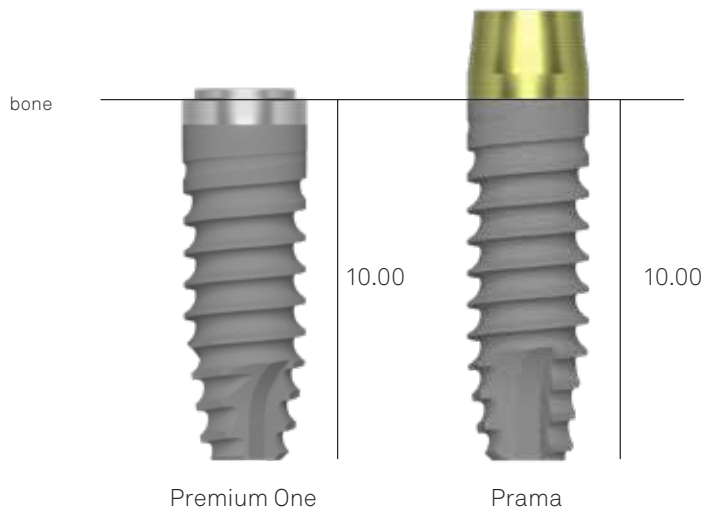

Introduction to the Echoplan PRO A system

There is a **fixed relationship** between the instruments involved in guided surgery which facilitates congruence between the implant position and its planned position. The ratio according to which the Echoplan PRO A system has been designed is **9.00 mm** between the level of the mechanical stop of instruments on the sleeve, the metal cylinder inserted in the surgical guide (which functions to guide the axis of the instruments' insertion but also to determine its place of rest at a determined length) and the implant connection plane (if using Premium One implants) or the edge between the transmucosal neck and treatment of the endosseous body (if using Prama implants). In order to respect this fixed 9.00 mm ratio, the tissue level implant mounters are not 9.00 mm long like those of the bone level implants but they measure 6.20 mm, that is, 9.00-2.80 mm (the length of the Prama neck).

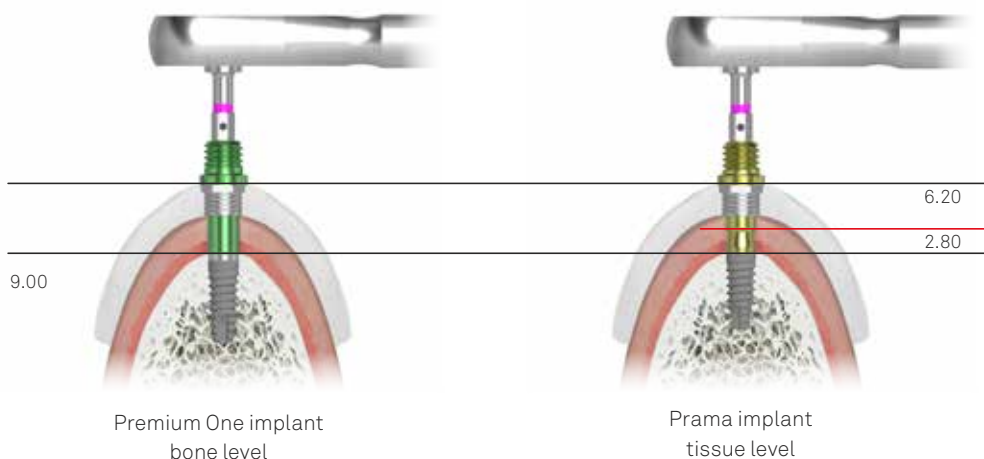

When a surgical protocol provides for a different positioning of the implant platform from the juxtaosseous as in the XA* technique, the digital planning automatically calculates the position of the sleeve's upper edge at exactly 9.00 mm from the connection plane. The thickness of the soft tissues in such cases may interfere with the ideal position of the sleeve so rather than adopting a flapless approach, the flap needs to be opened (**A**).

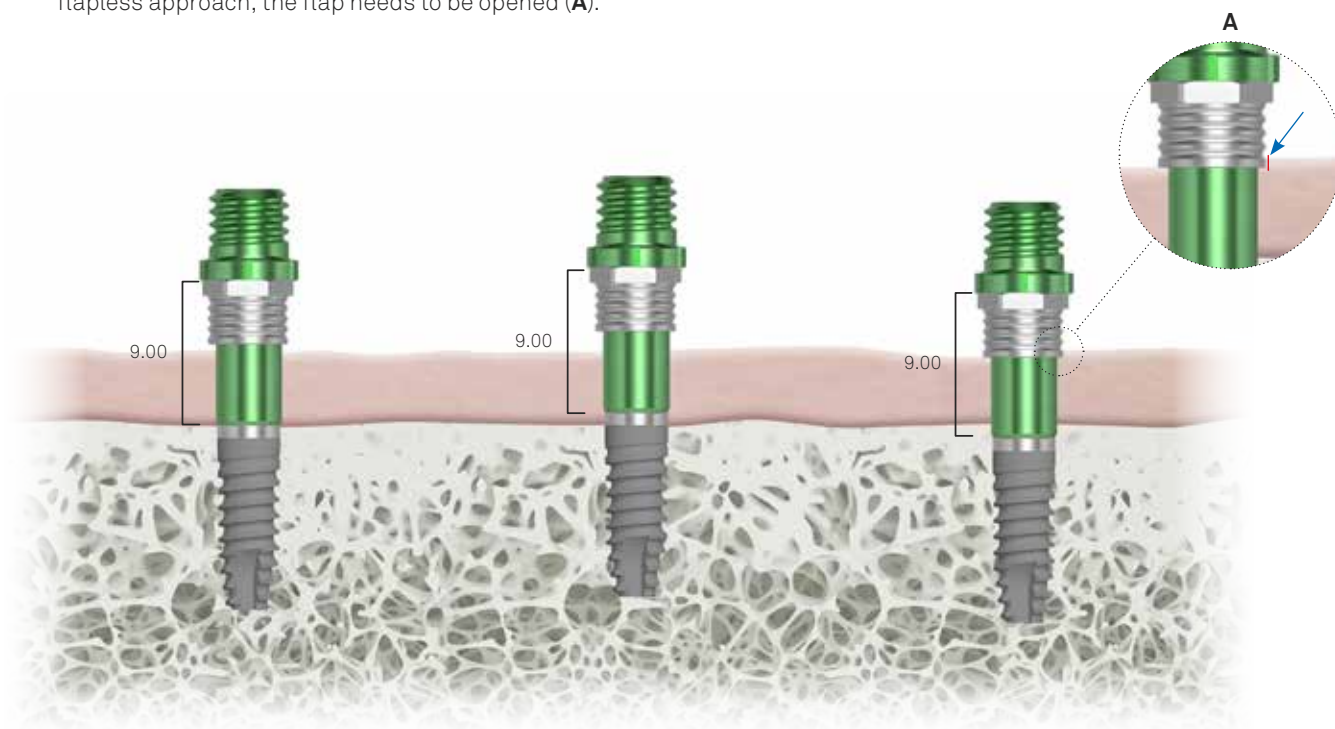

The opportunity to manage submerged positioning of implants is particularly helpful because the Premium One and Prama implant range also includes 6.00 mm and 7.00 mm heights and their dedicated drills are available as an option and can be added to the kit. In this case, please request the correct insertion sequence from Sweden & Martina.



*For further information on the XA technique, please go to www.sweden-martina.com





















Guide sleeves

The guide sleeves are AISI 630 stainless steel cylinders embedded in the polymer of the surgical guide to guide the rotating instruments during the preparation so that the planned axis of working is maintained using the planning software. They provide a definite physical stop for all instruments at 9.00 mm from the plane of the implant connection platform.

Sweden & Martina produces a series of standard sleeves, which are not indexed: these are available to laboratories who manufacture surgical guides using software different from RealGUIDE.

In addition, Sweden & Martina produces a series of indexed sleeves with an upper hexagon which means the positioning of the implant connection previously planned using RealGUIDE software can be respected. Due to this specific peculiarity, indexed sleeves can be positioned in Sweden & Martina surgical guides just using the appropriate software.



implant	∅ implant	sleeve		mounter	
Premium One	3.30 3.80	GS-B415  5.00 	GS-B415-EX-6*  4.00 	GS-MOU-A330  9.00	GS-MOU-A380  9.00
	4.25 5.00	GS-B550  5.00 	GS-B550-EX-6*  4.00 	GS-MOU-A380SP  9.00	
Prima	3.80	GS-B415  5.00 	GS-B415-EX-6*  4.00 	GS-MOU-L415  6.20	
	4.25 5.00	GS-B550  5.00 	GS-B550-EX-6*  4.00 	GS-MOU-L550  6.20	

*The indexed sleeves are available in packs of 6, not individually.

Important warning

Whenever a 3D printer is available to make the templates, it is appropriate to use the flow to bond the sleeves and not use cyano-methacrylate because the latter tends to oxidize them.

Implant mounters and connections

Premium One and Prama implants have the Collex One connection, with an internal prosthetic support hexagon that makes the prostheses robust and stable and acts as a guide when engaging the mounters. The connection is the same for all implant diameters but mounters differ according to the diameters of the reference guide sleeves (see the side table) within which the mounters must be guided for the 9.00 mm of their length. Please see pages 32-33 for all the codes and details of the interaction between mounters and the handpiece or the driver they must be used with.

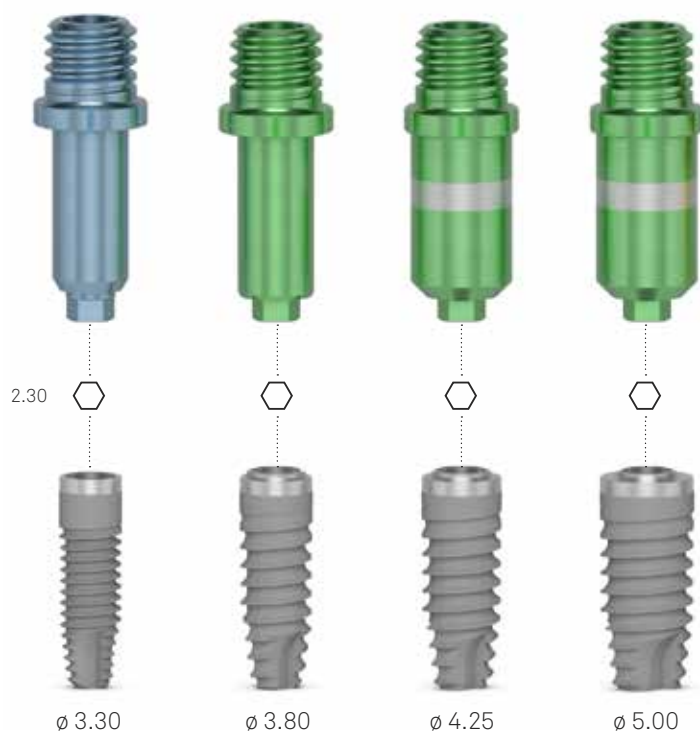

Prama mounters take the 2.80 mm length of the transmucosal neck into consideration, that is to say, the length guided in the sleeve is 6.20 mm (see page 7).

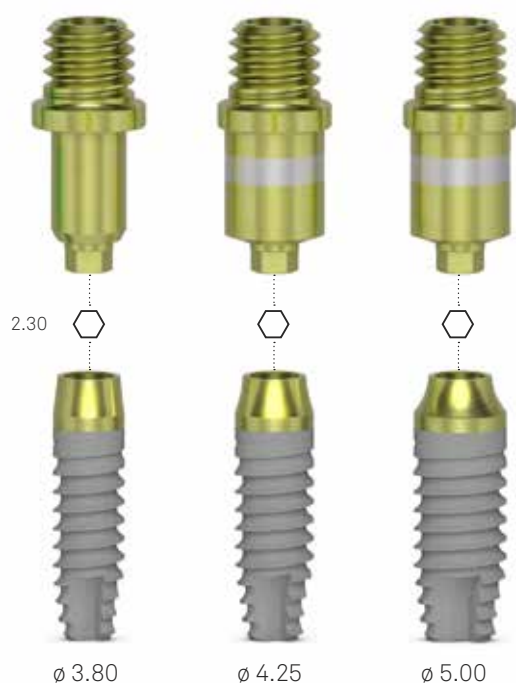

*Please see details of the Collex One connection inside the manuals MP-IMP-PREKOSH-ONE-E and MP-IMP-PRAMA-E at www.sweden-martina.com.

Easy Mounter





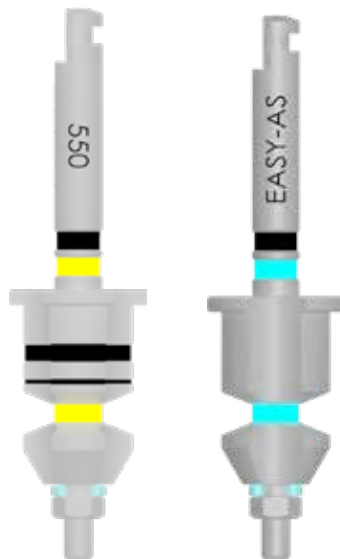

























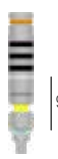

The Easy Mounters are instruments that function as drivers and as mounters without implant fixation screws, providing the advantage of simplicity and increased speed in usage. They are equipped with a predetermined safety fracture point, giving the clinician the assurance of being able to extract the driver even in the case of lever movements, very high torque, or fracture due to improper use. They are available in both the contra-angle and ratchet versions. The contra-angle version features colored rings that identify the reference bushing diameter, while in the ratchet version, the band that identifies the bushing is not present, but it is replaced by a laser marking on the head of the upper hexagon.

The Easy Mounters dedicated to the Prama implant are identified by yellow-colored rings, while those dedicated to the Premium implant have blue-colored rings. The Easy Mounters are not included in the kit but can be purchased separately and housed in the appropriate empty spaces on the tray.

















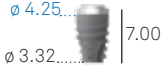















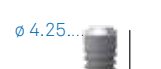

These Easy Mounters were designed to provide clinicians with greater freedom in implant insertion in post-extraction cases. This freedom is given by the fact that these instruments are entirely cylindrical, thus they have no shoulder to act as a stop (unlike other Easy Mounters).

The absence of a physical stop and the depth notches at each millimetre are also useful when, due to anatomical necessity, the guide sleeve is positioned at a greater height than the standard 9 mm reference used for Sweden & Martina guided surgical procedures.

implant	∅ implant	sleeve		mounter	
Premium One	3.30 3.80	GS-B415  5.00 	GS-B415-EX-6*  4.00 	GS-EASY-AS-415-EX  9.00	GS-EASY-AS-415-CA  9.00
	4.25 5.00	GS-B550  5.00 	GS-B550-EX-6*  4.00 	GS-EASY-AS-550-EX  9.00	GS-EASY-AS-550-CA  9.00
Prama	3.80	GS-B415  5.00 	GS-B415-EX-6*  4.00 	GS-EASY-L-415-EX  9.00	GS-EASY-L-415-CA  9.00
	4.25 5.00	GS-B550  5.00 	GS-B550-EX-6  4.00 	GS-EASY-L-550-EX  9.00	GS-EASY-L-550-CA  9.00
	3.80	GS-B415  5.00 	GS-B415-EX-6*  4.00 	GS-EASYPE-L-415-EX  9.00	GS-EASYPE-L-415-CA  9.00
	4.25 5.00	GS-B550  5.00 	GS-B550-EX-6  4.00 	GS-EASYPE-L-550-EX  9.00	GS-EASYPE-L-550-CA  9.00















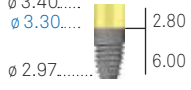



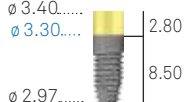

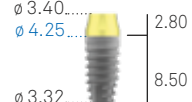

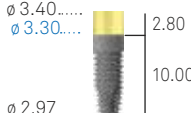
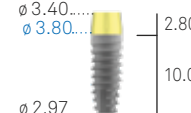
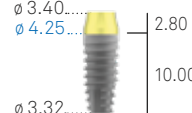

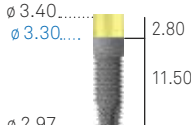
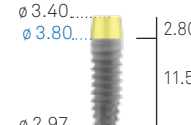
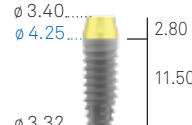
*The indexed sleeves are available in packs of 6, not individually.

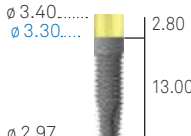
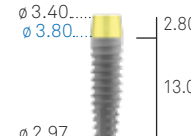
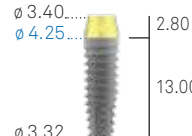
Premium One implants

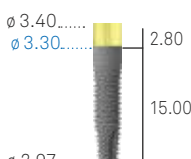
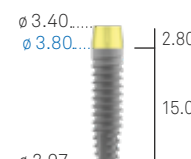
implant ϕ and color code on the packaging	3.30 	3.80 	4.25 	5.00 
7.00	-	-	AS-ZT-425-070  ϕ 4.25... ϕ 3.32... 7.00	AS-ZT-500-070  ϕ 5.00... ϕ 4.22... 7.00
8.50	A-ZT-330-085  ϕ 3.30... ϕ 2.52... 8.50	A-ZT-380-085  ϕ 3.80... ϕ 2.97... 8.50	AS-ZT-425-085  ϕ 4.25... ϕ 3.32... 8.50	AS-ZT-500-085  ϕ 5.00... ϕ 4.22... 8.50
10.00	A-ZT-330-100  ϕ 3.30... ϕ 2.52... 10.00	A-ZT-380-100  ϕ 3.80... ϕ 2.97... 10.00	AS-ZT-425-100  ϕ 4.25... ϕ 3.32... 10.00	AS-ZT-500-100  ϕ 5.00... ϕ 4.22... 10.00
11.50	A-ZT-330-115  ϕ 3.30... ϕ 2.52... 11.50	A-ZT-380-115  ϕ 3.80... ϕ 2.97... 11.50	AS-ZT-425-115  ϕ 4.25... ϕ 3.32... 11.50	AS-ZT-500-115  ϕ 5.00... ϕ 4.22... 11.50
13.00	A-ZT-330-130  ϕ 3.30... ϕ 2.52... 13.00	A-ZT-380-130  ϕ 3.80... ϕ 2.97... 13.00	AS-ZT-425-130  ϕ 4.25... ϕ 3.32... 13.00	AS-ZT-500-130  ϕ 5.00... ϕ 4.22... 13.00
15.00	A-ZT-330-150  ϕ 3.30... ϕ 2.52... 15.00	A-ZT-380-150  ϕ 3.80... ϕ 2.97... 15.00	AS-ZT-425-150  ϕ 4.25... ϕ 3.32... 15.00	AS-ZT-500-150  ϕ 5.00... ϕ 4.22... 15.00
18.00	-	A-ZT-380-180  ϕ 3.80... ϕ 2.97... 18.00	AS-ZT-425-180  ϕ 4.25... ϕ 3.32... 18.00	-
Surgical cover screws*	A-VT-330 	A-VT-380 	SH-VT-425-BL 	SH-VT-500-VI 

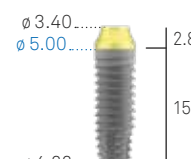









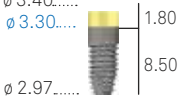
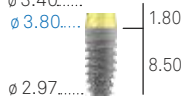
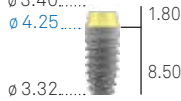
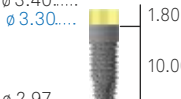

*Each implant is sold with the respective 4 Gr. titanium surgical cover screws. Individual surgical cover screws are also available in sterile packs and are tightened at 8-10 Ncm.

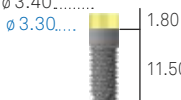
Prama implants

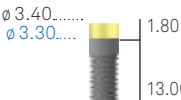
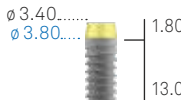
implant ϕ and color code on the packaging	3.30 	3.80 	4.25 	5.00 
6.00		LA-ZT-380-060 	LA-ZT-425-060 	LA-ZT-500-060 
8.50		LA-ZT-380-085 	LA-ZT-425-085 	LA-ZT-500-085 
10.00		LA-ZT-380-100 	LA-ZT-425-100 	LA-ZT-500-100 
11.50		LA-ZT-380-115 	LA-ZT-425-115 	LA-ZT-500-115 
13.00		LA-ZT-380-130 	LA-ZT-425-130 	LA-ZT-500-130 
15.00		LA-ZT-380-150 	LA-ZT-425-150 	LA-ZT-500-150 
Surgical cover screws		L-VT-340 	L-VT-340 	L-VT-340 













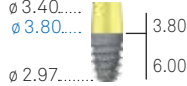
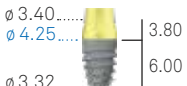

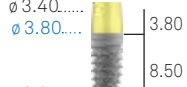
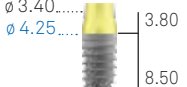

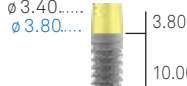
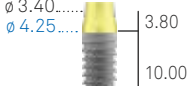

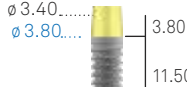
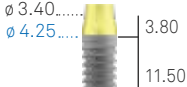
N. B.: the implant's nominal length expresses the endosseous length of the implant.
 Given the presence of the transmucosal neck, the total length is 2.80 mm greater than the nominal length.
 Each implant is sold with the respective 4 Gr. titanium surgical cover screws. Individual surgical cover screws are also available in sterile packs and are tightened at 8-10 Ncm.

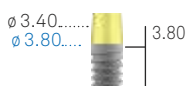
Prama Short neck implants

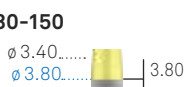
implant ϕ and color code on the packaging	3.80 	4.25 	5.00 
6.00	-	-	-
8.50	LAS-ZT-380-085 	LAS-ZT-425-085 	
10.00	LAS-ZT-380-100 	LAS-ZT-425-100 	
11.50	LAS-ZT-380-115 	LAS-ZT-425-115 	
13.00	LAS-ZT-380-130 	LAS-ZT-425-130 	
15.00	LAS-ZT-380-150 	LAS-ZT-425-150 	
Surgical cover screws	L-VT-340 	L-VT-340 	

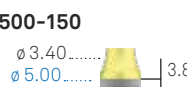
N. B.: the implant's nominal length expresses the endosseous length of the implant.
 Given the presence of the transmucosal neck, the total length is 1.80 mm greater than the nominal length.
 Each implant is sold with the respective 4 Gr. titanium surgical cover screws. Individual surgical cover screws are also available in sterile packs and are tightened at 8-10 Ncm.

Prama Long Neck implants

implant ϕ and color code on the packaging	3.80 	4.25 	5.00 
6.00	LA-ZT-380-060  ϕ 3.40..... ϕ 3.80..... ϕ 2.97.....	LA-ZT-425-060  ϕ 3.40..... ϕ 4.25..... ϕ 3.32.....	LA-ZT-500-060  ϕ 3.40..... ϕ 5.00..... ϕ 4.22.....
8.50	LA-ZT-380-085  ϕ 3.40..... ϕ 3.80..... ϕ 2.97.....	LA-ZT-425-085  ϕ 3.40..... ϕ 4.25..... ϕ 3.32.....	LA-ZT-500-085  ϕ 3.40..... ϕ 5.00..... ϕ 4.22.....
10.00	LA-ZT-380-100  ϕ 3.40..... ϕ 3.80..... ϕ 2.97.....	LA-ZT-425-100  ϕ 3.40..... ϕ 4.25..... ϕ 3.32.....	LA-ZT-500-100  ϕ 3.40..... ϕ 5.00..... ϕ 4.22.....
11.50	LA-ZT-380-115  ϕ 3.40..... ϕ 3.80..... ϕ 2.97.....	LA-ZT-425-115  ϕ 3.40..... ϕ 4.25..... ϕ 3.32.....	LA-ZT-500-115  ϕ 3.40..... ϕ 5.00..... ϕ 4.22.....
13.00	LA-ZT-380-130  ϕ 3.40..... ϕ 3.80..... ϕ 2.97.....	LA-ZT-425-130  ϕ 3.40..... ϕ 4.25..... ϕ 3.32.....	LA-ZT-500-130  ϕ 3.40..... ϕ 5.00..... ϕ 4.22.....
15.00	LA-ZT-380-150  ϕ 3.40..... ϕ 3.80..... ϕ 2.97.....	LA-ZT-425-150  ϕ 3.40..... ϕ 4.25..... ϕ 3.32.....	LA-ZT-500-150  ϕ 3.40..... ϕ 5.00..... ϕ 4.22.....
Surgical cover screws	L-VT-340 	L-VT-340 	L-VT-340 

N. B.: the implant's nominal length expresses the endosseous length of the implant.
 Given the presence of the transmucosal neck, the total length is 3.80 mm greater than the nominal length.
 Each implant is sold with the respective 4 Gr. titanium surgical cover screws. Individual surgical cover screws are also available in sterile packs and are tightened at 8-10 Ncm.

General indications

The surgical instruments designed for use with the implant systems manufactured by Sweden & Martina are reusable medical devices intended for temporary use in the oral cavity (no more than 60 minutes). The functions of the surgical instruments are to prepare sites for Sweden & Martina implants, to insert the implants in the sites, to tighten and unscrew all the connecting screws (surgical cover screws, healing abutments, screws for posts, abutments, prosthetic screws, transfer screws, etc.).

The surgical instruments manufactured by Sweden & Martina are designed for use with dental implants manufactured by Sweden & Martina. Use of surgical instruments for operations with other implants than those manufactured by Sweden & Martina limits the responsibility of Sweden & Martina and renders the product warranty void. Sweden & Martina declines all responsibility for use of any non-original instruments. Sweden & Martina surgical instruments are sold in **NON-STERILE packs**. Before use, they must be cleaned, disinfected and sterilized according to the instructions reported below. Failure to follow these warnings may expose the patient to infections. The materials used for production of the surgical instruments manufactured by Sweden & Martina were selected based on the properties indicated for their intended use according to Regulation (EU) Medical Devices n. 2017/745.

Each packaging indicates the code, description of the contents and batch number. These same details, which are also indicated on the labels inside the packs, must always be provided by the practitioner in any relevant correspondence.

All the devices are identified by an instrument code, which is laser marked onto the body of each instrument. If there is not enough space to include the full code, the elements for unequivocally identifying the device (e.g. diameter or length) are provided. When handling the devices, both during use and during cleaning and sterilization procedures, it is recommended to use surgical gloves for personal protection from bacterial contaminations. Failure to follow these instructions may cause cross-infection.

Key to codes: surgical instruments

Implants are coded with “mnemonic” codes that allow easy identification of the piece. Below is a table showing how the mnemonic codes work using various types of instruments as examples.

examples	component type and implant type	diameter	length	sleeve
The range of instruments is vast, we indicate some examples of the main families of instruments	The letters “GS” mean the instruments dedicated to guided surgery, designed to be guided inside the sleeves inserted in the surgical template	Normally it is the \varnothing of the implant for the insertion or of the preparation for which the instrument should be used	This measurement is normally linked to the height of the component, or to other important measurements that characterise it, or it is a value that defines the preparation length of a drill	Indicates the internal diameter of the sleeve guiding the instrument
GS-F200-100-415	GS-F: drill for guided surgery	200: 2.00 mm	100: for the preparation of 10.00 mm high implants	415: for sleeves of 4.15 mm diameter
GS-MUC-550	GS-MUC: mucotome for guided surgery	-	-	550: for sleeves of 5.50 mm diameter
GS-FPN-148	GS-FPN: drill for insertion of the surgical template retention pins	148: 1.48 mm	-	-

Echoplan PRO A surgical kit

The Echoplan PRO A surgical kit has been designed and produced to offer simplicity and immediacy of use for the correct sequence of the instruments. The instruments are all made of stainless steel for surgical use. They have the descriptions screen printed on the tray so that the user can easily identify each instrument and put it back in the correct place in the kit after the cleansing and cleaning phases thanks to the help of a system of color codes that track the appropriate surgical procedures for the various implant diameters.

Important warning

The Echoplan PRO A kit and the surgical instruments contained in it are sold in a NON-STERILE pack. Before being used, they must be cleaned, disinfected and sterilized according to the instructions provided below. Not respecting this warning may cause infections to the patient.

The kit has holders for the optional drills used to prepare the 6.00 mm and 7.00 mm short implants and the 18.00 mm long implants.



description	code
<p>Grommetless surgical kit complete with the Instruments required for guided insertion of Prama and Premium One implants</p> <p>Grommetless instrument cases made of Radel for the guided surgery instruments, empty</p>	<p>ZGS-PRO-A-INT</p>  <p>GSPROA-TRAY-INT</p>

Important warning

The kit does not contain mounters which must be bought separately before the surgical operation. Mounters can be stored and organized in an appropriate organizer. For details see pages 30-31 and 34.

1

Mucotomes
GS-MUC-415
GS-MUC-550



2

Bone profilers
GS-LC-415
GS-LC-550



3

Initial drills and progressive drill
GS-F200-415
GS-F200-550
GS-F2030-550



4

Drivers
HSM-20-EX HSML-20-EX HSM-20-DG HSML-20-DG HSM-20-CA



20

Optional drill for H 18.00 mm implants and ø 5.50 mm sleeve
GS-F200-180-550
GS-F340-180-550



19

Optional drill for H 18.00 mm implants and ø 4.15 mm sleeve
GS-F200-180-415
GS-F300-180-415



18

Pins and drill for pins
GS-FPN-148 GS-PIN (1 pc)



17

Hand knob
AVV3-MAN-DG



16

Torque control ratchet
CRI5-KIT



15

Drivers for mounters
EASY4-EX250-EX EASYC4-EX250-CA



14

Countersink drills
GS-FCS-A380
GS-FCS-A425
GS-FCS-A500

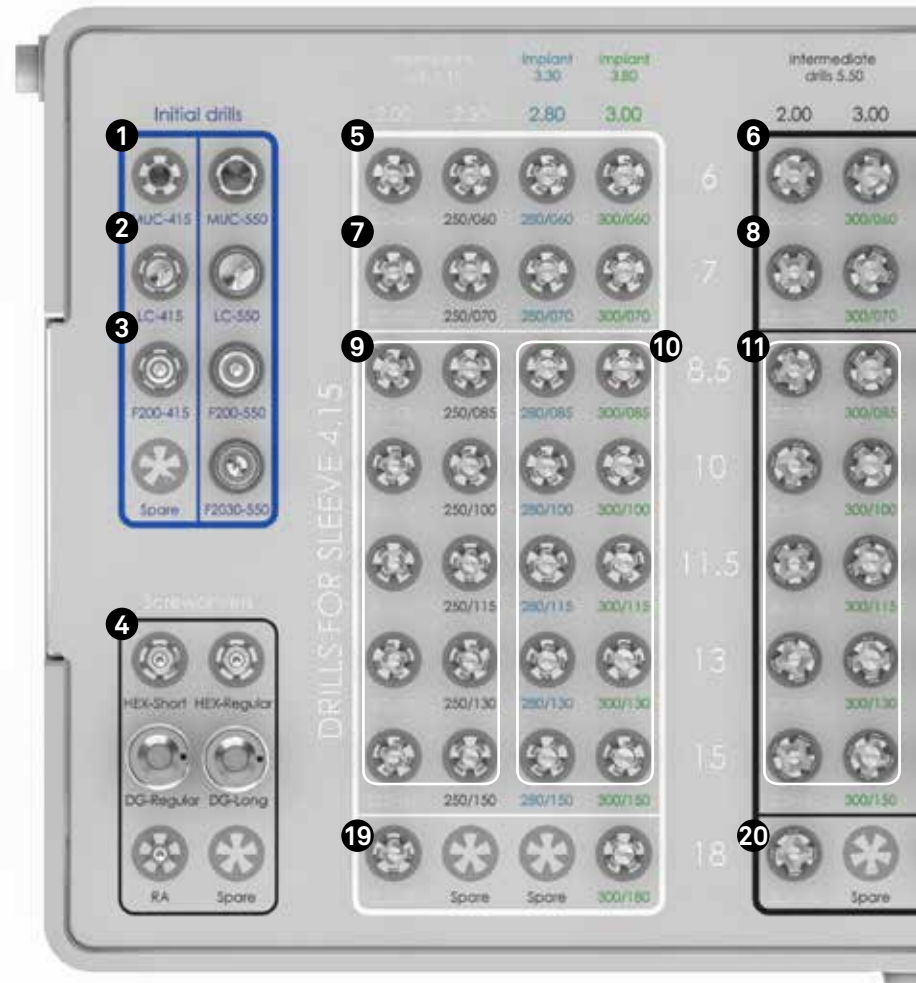

5

**Optional drills for H 6.00 mm
ø 3.80 mm implants**
GS-F200-060-415
GS-F250-060-415
GS-F280-060-415
GS-F300-060-415



6

**Optional drills for H 6.00 mm
ø 4.25 and 5.00 mm implants**
GS-F200-060-550
GS-F300-060-550
GS-F340-060-550
GS-F425-060-550



7

**Optional drills for H 7.00 mm
ø 3.80 mm implants**
GS-F200-070-415
GS-F250-070-415
GS-F280-070-415
GS-F300-070-415



8

**Optional drills for H 7.00 mm
ø 4.25 and 5.00 mm implants**
GS-F200-070-550
GS-F300-070-550
GS-F340-070-550
GS-F425-070-550



9

**Intermediate drills
for ø 4.15 mm sleeve**
GS-F200-085-415
GS-F200-100-415
GS-F200-115-415
GS-F200-130-415
GS-F200-150-415

GS-F250-085-415
GS-F250-100-415
GS-F250-115-415
GS-F250-130-415
GS-F250-150-415



10

**Final drills for
ø 4.15 mm sleeve**
GS-F280-085-415
GS-F280-100-415
GS-F280-115-415
GS-F280-130-415
GS-F280-150-415

GS-F300-085-415
GS-F300-100-415
GS-F300-115-415
GS-F300-130-415
GS-F300-150-415



11

**Intermediate drills for
ø 5.50 mm sleeve**
GS-F200-085-550
GS-F200-100-550
GS-F200-115-550
GS-F200-130-550
GS-F200-150-550

GS-F300-085-550
GS-F300-100-550
GS-F300-115-550
GS-F300-130-550
GS-F300-150-550

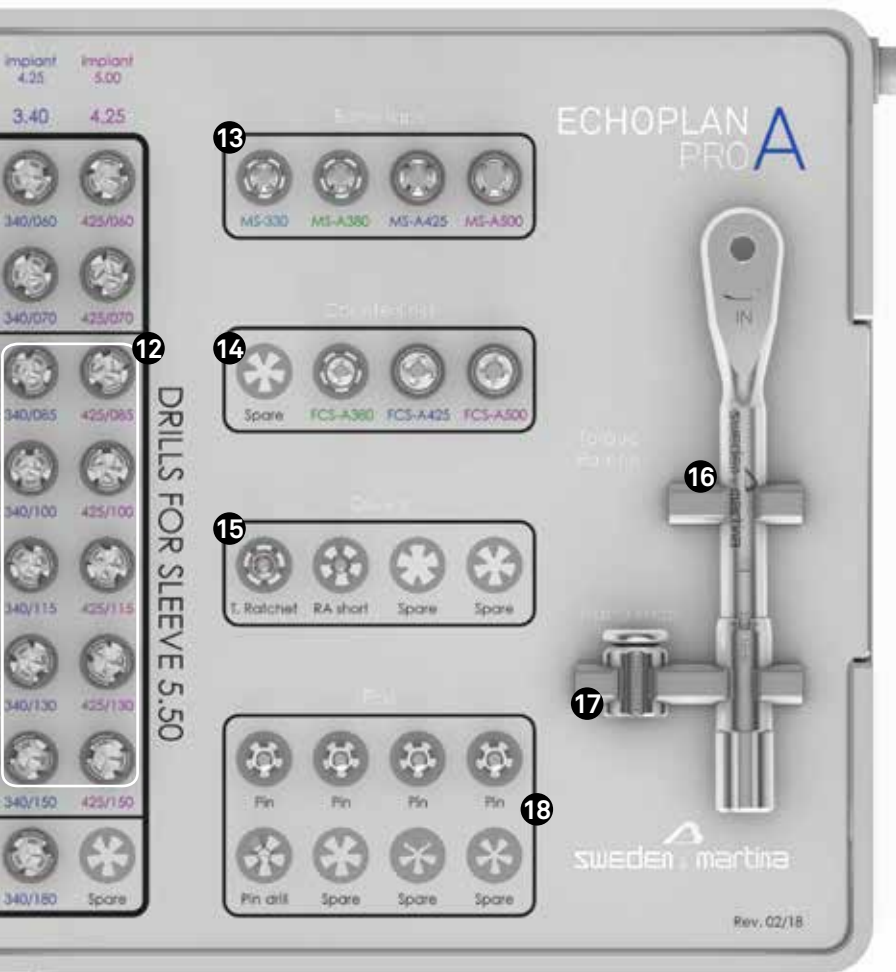

13

Bone taps
GS-MS-330
GS-MS-A380
GS-MS-A425
GS-MS-A500



12

Final drills for ø 5.50 mm sleeve
GS-F340-085-550
GS-F340-100-550
GS-F340-115-550
GS-F340-130-550
GS-F340-150-550

GS-F425-085-550
GS-F425-100-550
GS-F425-115-550
GS-F425-130-550
GS-F425-150-550



Rotating instruments

All Sweden & Martina drills are made of **surgical steel** with **high resistance to corrosion and wear**. They are intended for mechanical use, i.e. they have a shank with a right angle attachment and must be used with a suitable micromotor. The extreme accuracy of design and production allows use **completely free from vibrations and oscillations**. However, incorrect insertion of the instruments in the handpiece will cause instrument vibration, eccentric rotation, early wear and shaft buckling. Suitable surgical micromotors only should be used. Micromotors should be checked regularly by their manufacturers, according to the indications given by the manufacturers, to prevent potential malfunctions (e.g. axle shifts for transmission shafts, worn or faulty forceps, etc.).

Failure to follow the instructions provided may cause surgical complications and consequent damage to the patient's health. It is recommended to use the rotation speeds indicated in the procedures on page 60 and following to prevent the development of bone necrosis. Lever movements increase the risk of instrument breakage and should therefore be avoided. Changes in speed should be avoided in general. Never apply pressure such as to force the instrument to stop rotating. This could lead to an excessive increase in heat in the tissues being drilled, with consequent bone necrosis, and damage both the instrument and the appliance used (micromotor). This could also lead to breakage of the instrument. Using an intermittent approach, with a back and forth movement in a vertical direction, prevents overheating and wear of the working part and an undesirable increase in the temperature in the tissues being cut. Suitable coolant liquids must be used. Inadequate irrigation can lead to bone necrosis. Drill wear depends on a large extent on the type and density of the drilled bone: harder bone leads to greater instrument wear.

For greater safety and caution, given the device's capacity for resistance to wear, drills should not be used for more than **20 work cycles** and should be replaced earlier if the instruments lose their cutting ability. These recommended 20 cycles should be considered a rough guide. Always check the instrument's residual cutting capacity after each procedure. Sweden & Martina declines all responsibility in cases of excessively intense use. Never sharpen drills before use. Never use damaged, buckled or worn instruments.

Drills for guided surgery have been designed to work inside the sleeves produced by Sweden & Martina and inserted inside the surgical guides by the respective manufacturer. Sweden & Martina is not liable for any malfunctioning or damage caused by the use of guided surgery drills with non-original sleeves or incompatible with the size of instruments, which could get stuck, may not be guided correctly, or produce a different implant preparation from that planned by the clinician if the sleeve's height is not correct.

Important warning

The Echoplan PRO A kit and the surgical instruments contained in it are sold in a NON-STERILE pack. Before being used, they must be cleaned, disinfected and sterilized according to the instructions provided below. Not respecting this warning may cause infections to the patient.

Fixation pin and drills

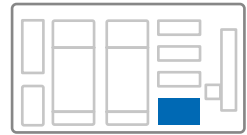

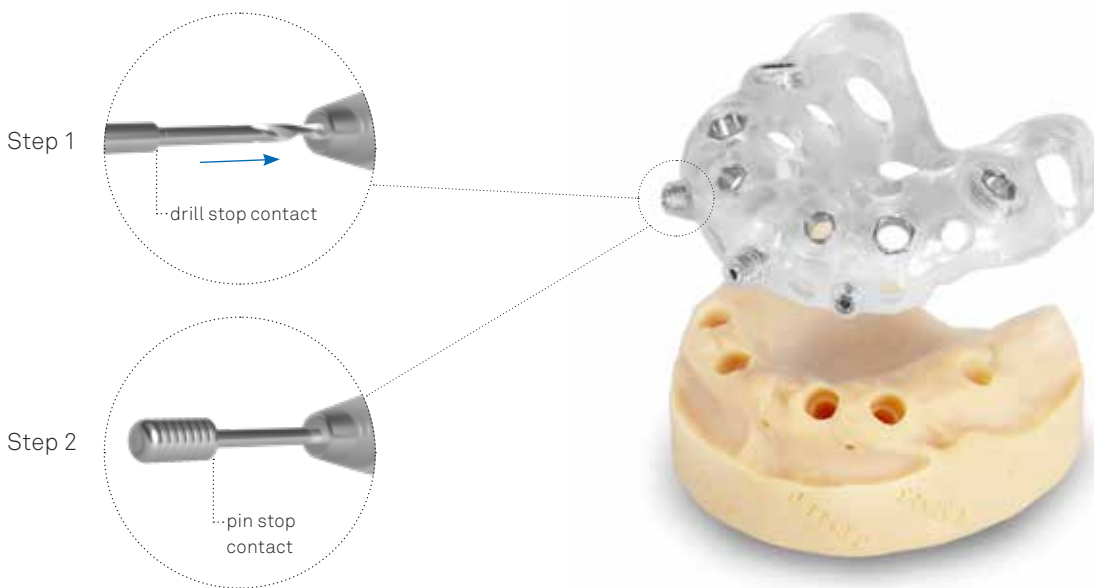

When the surgical template cannot be stabilized on the residual teeth, it is appropriate to adopt a protocol with a total-thickness flap that guarantees bone support. However, since the edentulous arch would allow tilting, the template needs to be stabilized using the Gr. 5 titanium bone pins included in the kit. In order to prepare the pin's recessed hole, the related GS-FPN-148 drill is provided, to be used at 800 rpm.

The pins are guided into the appropriate dedicated sleeves which are provided by Sweden & Martina already inserted in the template without additional cost. Should the templates be made in laboratory, the sleeves can be purchased separately in packs of 6. They are not sold individually.



Important warning

In order to stabilize the template correctly, both the drill and the pin must reach the final stop contact.

description	code
Drill for fixation pin	GS-FPN-148 
Fixation pin 1 item pack	GS-PIN 
Sleeves for pins 6 item pack	GS-B150-PIN-6 

From planning to implant insertion: stages in Echoplan guided surgery

Thanks to the potential of 3D simulation, the clinician is able to define exactly the diameter and height of the implant to be inserted using one of the numerous softwares on the market. The correct implant positioning is referred to the operator’s clinical experience and to the accuracy of the chosen software. The Echoplan PRO A kit can be used with all softwares respecting a stop contact distance for the instruments fixed at 9.00 mm from the implant platform.

The choice of the guide sleeve to be inserted in the template is made by the template manufacturer and is bound by the diameter of the implant chosen. See page 8 for information about the sleeves that Sweden & Martina manufactures for the production of the surgical templates. After identifying the diameter of the sleeve to be used, it is possible to prepare the surgical site using the appropriate surgical instruments from the Echoplan PRO A kit for the sleeve diameter.

Site preparation **must** proceed with the sequential use of three surgical accessories included in the kit, which are the following: mucotome, the bone profiler and the initial drill. The shape of the drill tips allows a hole with a diameter of 2.00 mm and a depth of 4.50 mm (A) to be bored. In this way the final drills that are used subsequently are guided from the first millimetres onwards at the tip (for 4.50 mm by the hole bored by the initial drill) and in the guide sleeve. The illustration below visually helps to understand the importance of these three initial steps. All three instruments are included in the kit in both the versions for the \varnothing 4.15 mm and the \varnothing 5.50 mm sleeve.

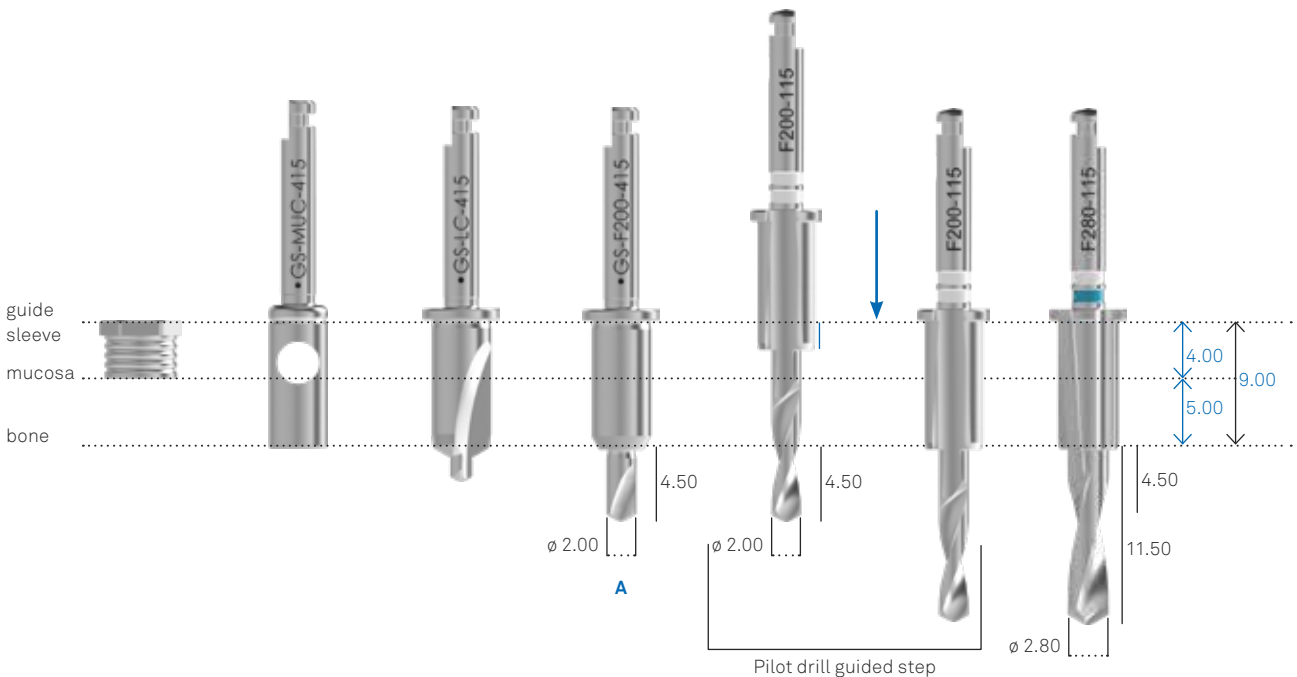



Surgical instruments for the initial phase

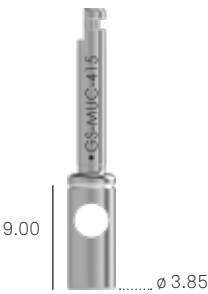

Mucotomes GS-MUC-415 and GS-MUC-550

The kit contains two mucotomes, one for each sleeve diameter. Since they only have to core the mucosa and are used in the first surgical step, they have no predetermined stop. The mucotomes have an indented notch at 9.00 mm, as a visual reference. The two mucotomes create a modest over-preparation of the mucosa to avoid direct contact with the drills.

Description	For \varnothing 4.15 mm sleeve	For \varnothing 5.50 mm sleeve
Mucotomes for guided surgery	<p>GS-MUC-415</p>  <p>9.00 \varnothing 3.85</p>	<p>GS-MUC-550</p>  <p>9.00 \varnothing 5.00</p>

Crestal bone levellers GS-LC-415 and GS-LC-550

The crestal levellers have a dual function. They drill a very shallow hole that will guide the tip of subsequent instruments whilst also eliminating any irregularities in the bone crest. This is precisely why there is a cutting edge on the oblique profile at the tip of the part that is guided by the sleeve.

Description	For \varnothing 4.15 mm sleeve	For \varnothing 5.50 mm sleeve
Crestal levellers for guided surgery	<p>GS-LC-415</p>  <p>1.76 \varnothing 1.50</p>	<p>GS-LC-550</p>  <p>1.63 \varnothing 1.50</p>



Initial drills GS-F200-415 and GS-F200-550

The third compulsory stage involves two initial drills, one for each sleeve diameter, to be used always regardless of the implant system. The drills create a hole with a depth of 4.50 mm, so that the subsequent drills can be guided doubly, both at the tip, because this is inserted in the guide hole already drilled, and by the stop that is guided inside the sleeve at a higher position.

Description	For \varnothing 4.15 mm sleeve	For \varnothing 5.50 mm sleeve
Initial drills for guided surgery	<p>GS-F200-415</p>	<p>GS-F200-550</p>

Progressive drill GS-F2030-550

To facilitate the transition to larger diameters, a progressive drill is available, which widens the preparation from \varnothing 2.00 mm to \varnothing 3.00 mm, allowing the intermediate drills with \varnothing 3.00 mm for a sleeve with \varnothing 5.50 mm to be guided through it. The drill should be used after the intermediate drill with \varnothing 2.00 mm. For the correct sequence of using the progressive drill, please refer to the sequences on page 44.

Description	For \varnothing 5.50 mm sleeve
Progressive drill \varnothing 2.00 - 3.00 mm	<p>GS-F2030-550</p>

Intermediate and final drills



Given the shared cylindrical morphology of the body of Premium One and Prama implants, the same drills are used to prepare both their sites. All of the drills in the Echoplan PRO A system are cylindrical with helical geometry: those up to a diameter of 3.00 mm are characterized by two cutting edges while the drills over 3.00 mm in diameter have three blades.

Each drill has two indications on its shaft: on the one side, the diameter of the sleeves with which it is used (**side B**) and on the other side, a code composed of the cutting edges diameter and the height of the corresponding implant, in this order (**side A**).

The image below shows how for example the first part in the code F425-115 identifies the width of the preparation, that is, the diameter of the working part of the 4.25 mm drill which is used as the final drill for a \varnothing 5.00 mm implant, while the second part states the implant's length of 11.50 mm.

Drills are also characterized by a colored double ring at the foot of the shaft. This color is a code that along with the upper band identifies the sleeve's diameter (**ring A**: white for the \varnothing 4.15 mm sleeve and black for the \varnothing 5.50 mm sleeve) and with the lower band identifies the diameter of the cutting edge that in the case of the final drills refers to the color of the sticker on the fixture's pack (**ring B**). See the headings of the tables on pages 12-13 for the implant diameters corresponding to the color codes.

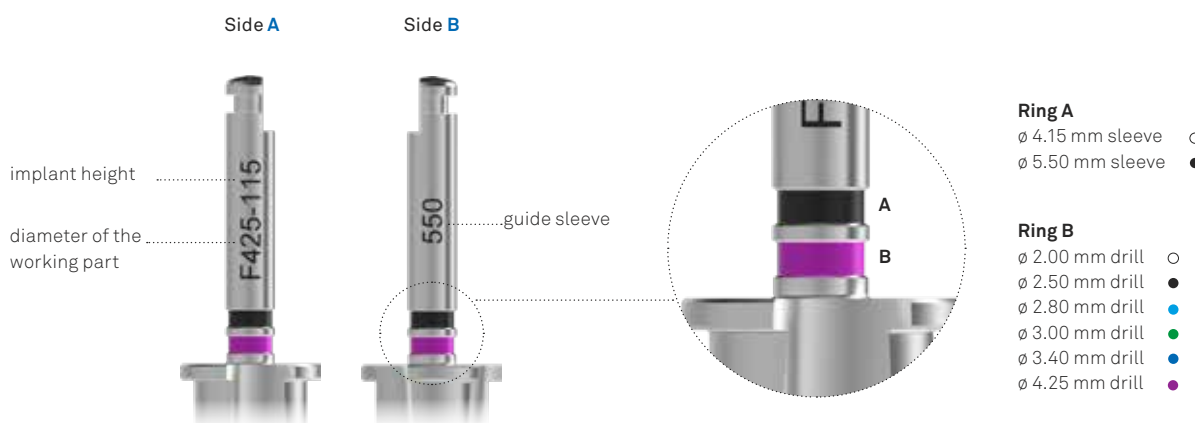

Intermediate drills have black and white rings only. Please find all the details in the tables on the following pages.







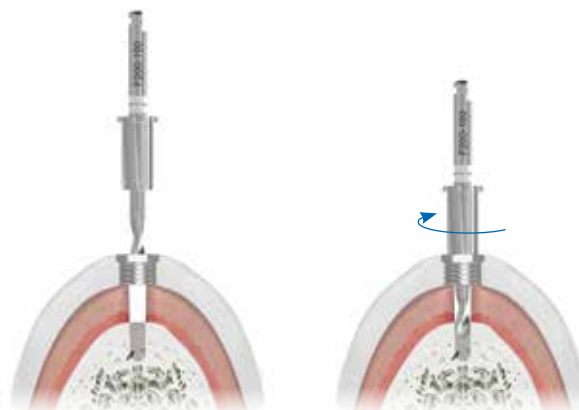



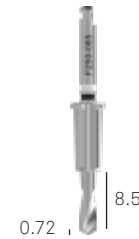
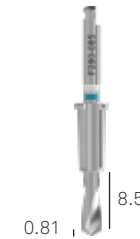







Stops are integrated into the drills' shaft for a faster and more ergonomic work. Where possible, **the rotation of the drill should only be started when the stop is engaged into the sleeve.**

In order to guarantee maximum accuracy, it is advisable to irrigate the implant site abundantly with a sterile physiological solution (NaCl) during and after the preparation to facilitate the expulsion of bone residues that may obstruct the correct functioning of the instruments. The irrigation will also help prevent the drill from overheating and consequently the surrounding tissues: to facilitate the passage of the liquid, the intermittent drilling technique is probably the most useful.













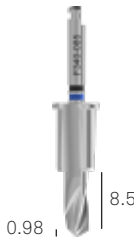



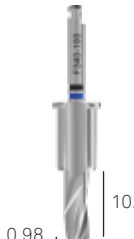



Before each intervention, check that the drills are in good condition and substitute them if necessary.



Drills provided with the Echoplan PRO A kit









description	for \varnothing 4.15 mm sleeve			
Drills for preparing H 8.50 mm implants	GS-F200-085-415  0.58 8.50	GS-F250-085-415  0.72 8.50	GS-F280-085-415  0.81 8.50	GS-F300-085-415  0.86 8.50
Drills for preparing H 10.00 mm implants	GS-F200-100-415  0.58 10.00	GS-F250-100-415  0.72 10.00	GS-F280-100-415  0.81 10.00	GS-F300-100-415  0.86 10.00
Drills for preparing H 11.50 mm implants	GS-F200-115-415  0.58 11.50	GS-F250-115-415  0.72 11.50	GS-F280-115-415  0.81 11.50	GS-F300-115-415  0.86 11.50
Drills for preparing H 13.00 mm implants	GS-F200-130-415  0.58 13.00	GS-F250-130-415  0.72 13.00	GS-F280-130-415  0.81 13.00	GS-F300-130-415  0.86 13.00
Drills for preparing H 15.00 mm implants	GS-F200-150-415  0.58 15.00	GS-F250-150-415  0.72 15.00	GS-F280-150-415  0.81 15.00	GS-F300-150-415  0.86 15.00



description	for \varnothing 5.50 mm sleeve			
Drills for preparing H 8.50 mm implants	GS-F200-085-550  0.58 8.50	GS-F300-085-550  0.86 8.50	GS-F340-085-550  0.98 8.50	GS-F425-085-550  1.22 8.50
Drills for preparing H 10.00 mm implants	GS-F200-100-550  0.58 10.00	GS-F300-100-550  0.86 10.00	GS-F340-100-550  0.98 10.00	GS-F425-100-550  1.22 10.00
Drills for preparing H 11.50 mm implants	GS-F200-115-550  0.58 11.50	GS-F300-115-550  0.86 11.50	GS-F340-115-550  0.98 11.50	GS-F425-115-550  1.22 11.50
Drills for preparing H 13.00 mm implants	GS-F200-130-550  0.58 13.00	GS-F300-130-550  0.86 13.00	GS-F340-130-550  0.98 13.00	GS-F425-130-550  1.22 13.00
Drills for preparing H 15.00 mm implants	GS-F200-150-550  0.58 15.00	GS-F300-150-550  0.86 15.00	GS-F340-150-550  0.98 15.00	GS-F425-150-550  1.22 15.00

Optional drills for 6.00 and 7.00 mm heights



The surgical kit contains all of the instruments for inserting implants of lengths between 8.50 mm and 15.00 mm. It also includes empty slots to insert the optional drills to prepare sites 6.00, 7.00 and 18.00 mm in length. Such optional drills can be purchased individually or in sets that cover all of the implant diameters for each special height.

sleeve	ø 4.15 mm			
Drill for preparing H 6.00 mm* ø 3.80 mm implants	GS-F200-060-415  0.58 6.00	GS-F250-060-415  0.72 6.00	GS-F280-060-415  0.81 6.00	GS-F300-060-415  0.86 6.00
Drill for preparing H 7.00 mm** ø 3.80 mm implants	GS-F200-070-415  0.58 7.00	GS-F250-070-415  0.72 7.00	GS-F280-070-415  0.81 7.00	GS-F300-070-415  0.86 7.00

*The drills for preparing implants 6.00 mm high can also be ordered in a full set using the code **GS-PROA-INTEGRA-060**.

The drills for preparing implants 7.00 mm high can also be ordered in a full set using the code **GS-PROA-INTEGRA-070.

Optional drills for 18.00 mm heights

sleeve	ø 4.15 mm	
Drill for preparing H 18.00 mm ø 3.80 mm implants	GS-F200-180-415  0.58 18.00	GS-F300-180-415  0.86 18.00

N.B. in contrast to the sets of drills for the 6.00 and 7.00 mm high implants, the drills for preparing implants 18.00 mm high can only be purchased individually.



sleeve	ø 5.50 mm			
Drill for preparing H 6.00 mm* ø 4.25 and 5.00 mm implants	GS-F200-060-550 0.58 6.00	GS-F300-060-550 0.86 6.00	GS-F340-060-550 0.98 6.00	GS-F425-060-550 1.22 6.00
Drill for preparing H 7.00 mm** ø 4.25 and 5.00 mm implants	GS-F200-070-550 0.58 7.00	GS-F300-070-550 0.86 7.00	GS-F340-070-550 0.98 7.00	GS-F425-070-550 1.22 7.00

*The drills for preparing implants 6.00 mm high can also be ordered in a full set using the code **GS-PROA-INTEGRA-060**.

The drills for preparing implants 7.00 mm high can also be ordered in a full set using the code **GS-PROA-INTEGRA-070.

sleeve	ø 5.50 mm	
Drill for preparing H 18.00 mm ø 4.25 and 5.00 mm implants	GS-F200-180-550 0.58 18.00	GS-F340-180-550 0.98 18.00





N.B. in contrast to the sets of drills for the 6.00 and 7.00 mm high implants, the drills for preparing implants 18.00 mm high can only be purchased individually.

Bone taps



These are bladed instruments able to prepare bone to receive the implants' thread, in very compact or cortical bone in order to alleviate the compression and decrease the insertion torque. All of the bone taps have a total length of insertion in the bone of 6.00 mm and are composed of a guide section that does not cut, and a cutting section of 5.50 mm, independent from the length of the implant to be inserted. Each implant diameter has a dedicated bone tap. Premium One and Prama systems have the same bone taps because they share the same endosseous morphology.



description	ø 3.30	ø 3.80	ø 4.25	ø 5.00
Bone taps for Premium One and Prama implants	GS-MS-330  6.00	GS-MS-A380  6.00	GS-MS-A425  6.00	GS-MS-A500  6.00

Important warning

Even in very mineralized bone it is not advisable to bone tap the preparations for 6.00 and 7.00 mm height implants.

Countersink drills



In the case of excessive friction caused by the coronal cortical bone, the neck of the implant can be prepared using the appropriate four-edged countersink drills included in the surgical kit. The countersink drills are universal because they can be used for both a cylindrical preparation for the neck of Premium One implants and for the cylindrical portion of Prama implants.





description	ø 3.30	ø 3.80	ø 4.25	ø 5.00
Countersink drills for Premium One and Prama implants	-	GS-FCS-A380	GS-FCS-A425	GS-FCS-A500

Important warning
 Even in very mineralized bone it is not advisable to use the countersink drill for the preparations of 6.00 mm height implants.

Drivers for connecting screws



The surgical kit contains several useful screwdrivers for tightening and unscrewing mounter fixation screws, healing abutments, transfer screws, post and abutments screws. All of the screwdrivers are made of stainless steel for surgical use. The design of the tip of all of the screwdrivers is the same so they are all interchangeable. They are available in different total lengths and in digital and one-piece version, that is to say, solid with a handpiece that can be gripped, or equipped with a hexagonal connector compatible with the ratchet. The one-piece hand drivers in the kit are available in two different heights.

description	code
Hand driver for surgical cover screws and fixation screws, digital, short	<p>HSM-20-DG</p> 
Hand driver for surgical cover screws and fixation screws, digital, long	<p>HSML-20-DG</p> 

Important warning
It is recommended to pass a thread through the hole on the top of the digital screwdriver to prevent it from falling.



Important warning
Lever movements should be avoided as they increase the risk of breakage. Before tightening, make sure the hexagonal socket screw head on the driver tip is correctly inserted into the screws to be tightened. Incorrect insertion is likely to pare off the hexagonal connection of the screwdriver or the screw to be tightened. Drivers have a slightly conical profile, able to guarantee the hexagonal connection on the tip of the drivergrips inside the hexagonal connection on the head of the screws, making it possible to carry the screw to the patient's mouth correctly, without dropping it. Replace drivers regularly to reduce the risk of wear to the hexagon connection.

Important warning
Excessive torque can strip the fixation screws' slots and round off the corners of the screwdrivers causing intraoperative or prosthetic complications that can be serious. The recommended torques for tightening the various components are summarized in the following table:

description	recommended torque
surgical cover screws, healing abutments	(manually) 8-10 Ncm
all of the prosthetic screws	20-25 Ncm
all of the prosthetic components with direct screw retention on the implant	25-30 Ncm
transfer fixation screws	(manually) 8-10 Ncm



Prosthetic screwdrivers

In order to facilitate the engagement of the screws or the threaded portions of the prosthetic components, tightening can be started using the digital screwdrivers. Nevertheless, given the importance of the tightening torque, it is advisable to use screwdrivers with hexagonal connectors in this phase, keeping the torque under control with the applied use of the torque wrench.

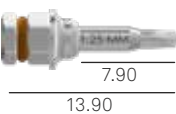
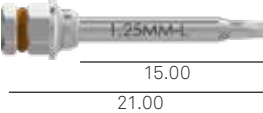
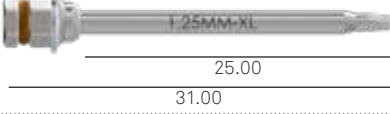
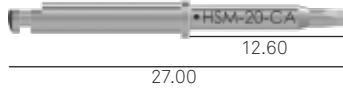
description	code
Screwdriver for fixation screws, with hexagonal connector for torque control ratchet or hand knob, short	<p>HSM-20-EX</p> 
Screwdriver for fixation screws, with hexagonal connector for torque control ratchet or hand knob, long	<p>HSML-20-EX</p> 
Screwdriver for fixation screws, with hexagonal connector for torque control ratchet or hand knob, extra long*	<p>HSMXL-20-EX</p> 
Screwdriver, with right angle shank for fixation screws	<p>HSM-20-CA</p> 

*Optional instrument not included in the surgical kit but purchased separately

Important warning

All the ratchet drivers have a red polymer O-ring in the connecting hexagon that guarantees friction between the instruments and therefore a correct grip of the components. This O-ring must be checked periodically and replaced when worn or when no longer able to exert the correct friction. A kit of 5 spare O-rings is available, which can be ordered with code **ORING180-088**.

Hand knob

description	code
Hand knob for bone taps, mounters, drivers and manual drivers	<p>AVV3-MAN-DG</p> 

Mounters

Mounters are used to ensure that final implant insertion is also guided, not only in terms of angle and depth but also of orientation. In fact, mounters have a hexagonal landmark with faces aligned with the faces of the implant connections (**A**). They are made in 5 Gr. Titanium, anodized according to the color code shown in the table below and are supplied together with the specific screw, the same for all implant diameters, to be tightened manually with a torque no greater than 10 Ncm.

Mounters can be organized, sterilized and preserved in the dedicated Mounter Organizer illustrated on page 38.

Mounters for Premium One implants





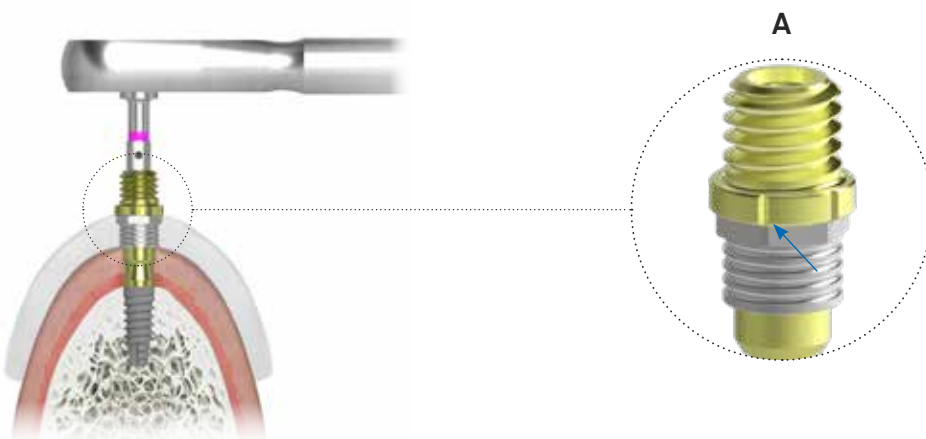

















Mounters for Prama implants



Important warning

In order to meet the clinical needs of every individual case, both Premium One and Prama implants can be positioned more deeply (see page 7). For help in advance in the planning stage of these cases, it is advisable to call Sweden & Martina personnel dedicated to guided surgery. The support service for guided surgery can be contacted by phone on 08007747542.

\varnothing Premium One	3.30	3.80	4.25	5.00
implant color code				
mounter color code	GS-MOU-A330 	GS-MOU-A380 	GS-MOU-A380SP 	GS-MOU-A380SP 
fixation screws supplied as standard	GS-VTMOU-180 	GS-VTMOU-180 	GS-VTMOU-180 	GS-VTMOU-180 



\varnothing Prama	3.80	4.25	5.00
implant color code			
mounter code	GS-MOU-L415 	GS-MOU-L550 	GS-MOU-L550 
fixation screws supplied with the mounter	GS-VTMOU-180 	GS-VTMOU-180 	GS-VTMOU-180 

Easy Insert Driver for mounters

The Echoplan PRO A surgical kit includes two Easy Insert drivers with a metal O-ring that clicks inside the upper end of all of the mounters, making certain of the assembled implant-mounter's transport into the sleeve and of the surgical insertion phases.

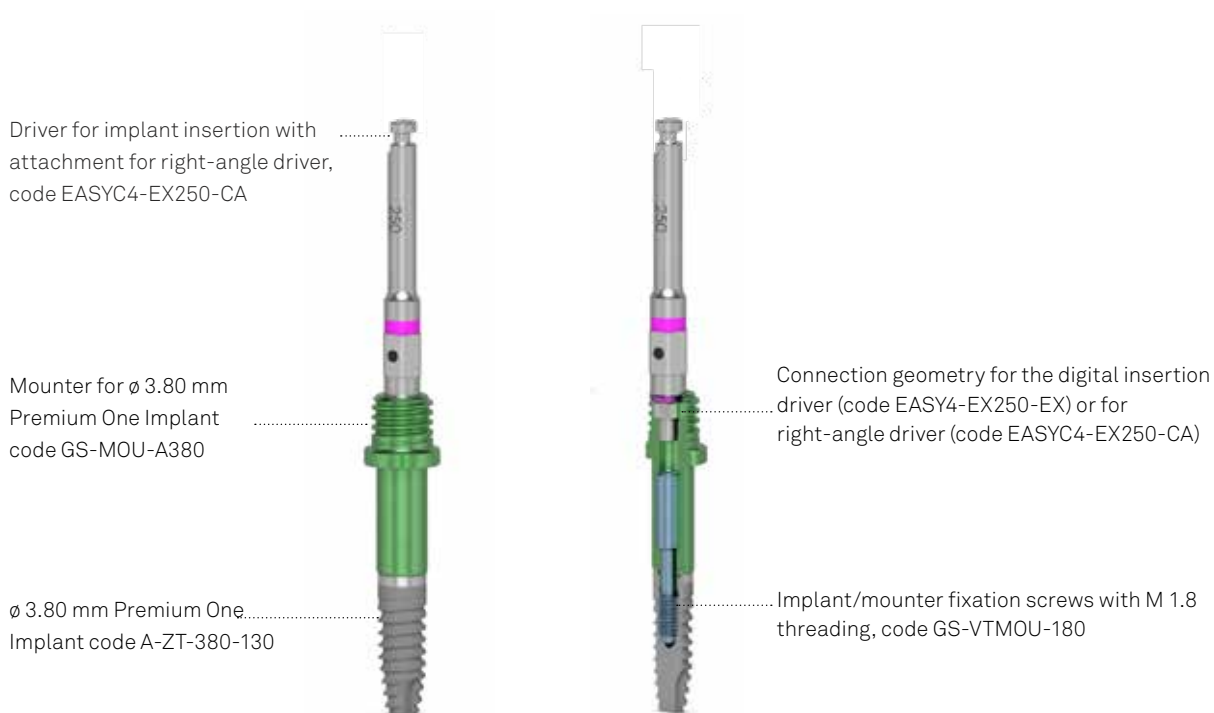
These drivers have been tested up to a torque of 70 Ncm. Greater insertion torque can cause mechanical criticality. It is advisable to use Easy Insert with hexagon in all of the later inserting phases.



description	code
Easy Insert Driver for guided surgery mounters with hexagonal connector for torque control ratchet	EASY4-EX250-EX 
Easy Insert Driver for guided surgery mounters with right-angle attachmen	EASYC4-EX250-CA 

Important warning

The Easy Insert drivers for mounters cannot be used to directly engage Premium One and Prama implants: their dimensions only allow them to be used with guided surgery mounters.

They are supplied pre-mounted with the appropriate titanium O-ring. Being mechanical components, these small retention rings are subject to wear and can lose their elasticity and functionality with the passage of time and cannot be replaced. On the other hand, the instrument in its entirety can be replaced.

Easy Inserts have been tested to resist up to 50 uses in the most unfavorable use conditions. Consequently, this limit can vary according to the conditions of use. They have a guiding pin on the tip that facilitates insertion into the moulder. Lever movements can cause the driver to bend or fracture with intraoperative surgical complications being possible.

Hand knob for removal of the GS-MOU-DG mounter

This optional hand knob can be useful after the implant insertion and mounter screw removal for a guided extraction and removal of the mounter, without compromising primary stability of the the implant. The hand knob can be sterilized and kept in the appropriate slot inside the Mounter Organizer (page 38).

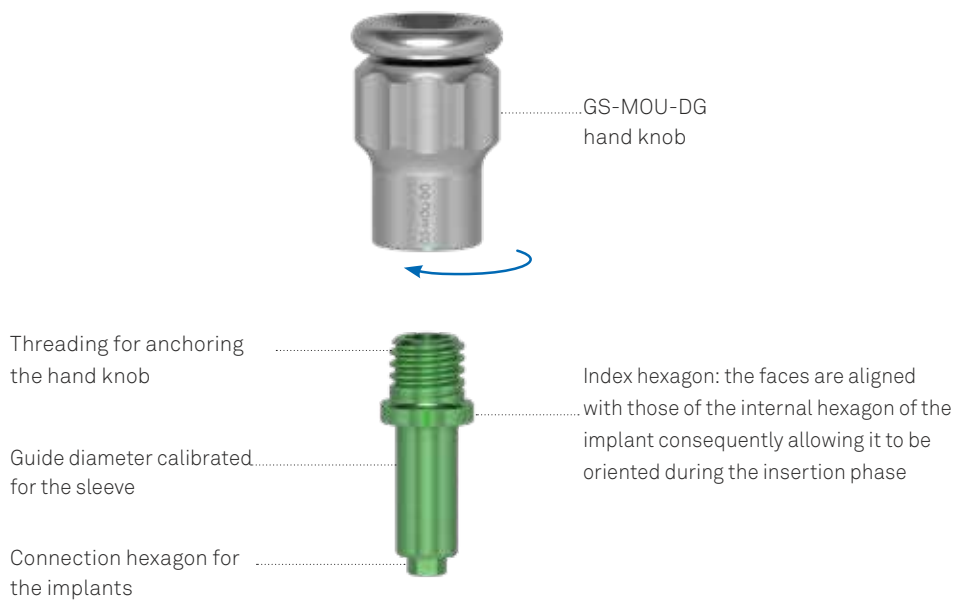

Important warning

The connecting screw between the implant and the mounter must be removed prior to the hand knob being employed.

Mounter Organizer GSMOUNT-TRAY-INT

The Mounter Organizer is an autoclavable Radel tray designed to organize, sterilize and store guided surgery mounters. In the upper half there are two areas each with 20 slots to divide the instruments according to the size of the sleeve they are to be used with. There is a removable surgical steel tray for storing used instrument holders after removal in the centre of the tray. In the lower half of the tray there is a retainer for the manual handpiece, 4 slots for hexagonal and contra-angle instruments, and 7 secured slots for implant vials that aid the assembly of the mounter to the fixture.

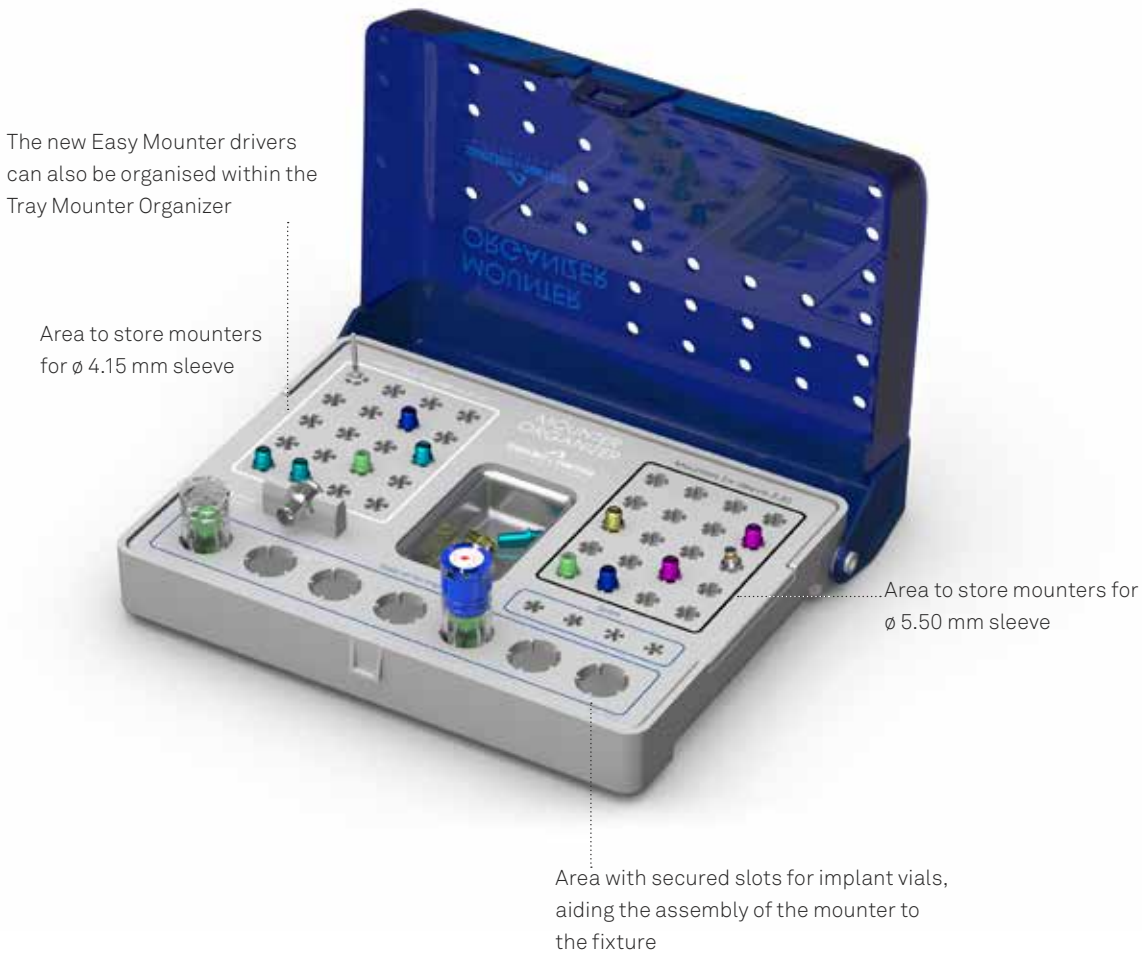

Important Warning

The Mounter Organizer tray is sold empty, and does not include any tools. The surgical steel tray should be removed for cleaning and can be reassembled before being sterilised.

A comparison of the control lever TWL and CRI5-KIT

The surgical kit includes a special torque wrench with control lever (TWL). The torque wrench can be used to indicate the torque applied during the surgical phases of screwing and unscrewing, showing values from 10 to 90 Ncm. It is supplied complete with a specific adaptor that allows it to be used with surgical instruments with a hexagonal connection.



The torque wrench can also be used as a fixed key, without using the scale, by using the entire handle as a lever. In this case, it must not exceed the torque value of 150 Ncm.

On the other hand, it is not possible to use this torque wrench, which is why the CRI5-KIT torque ratchet is recommended for the temporary, laboratory and final stages of rehabilitation.

The torque ratchet is not included in the surgical kit but can be ordered separately (using the code **CRI5-KIT**) and is supplied with the torque adjustment and maintenance instruments.



For the use of the CRI5-KIT in the tightening of the fixation and prosthetic screws, please refer to the torque values on page 34 and in the sequence of use. The ratchet key CRI5-KIT is a multi-purpose instrument that can be disassembled, and is sold non-sterile.

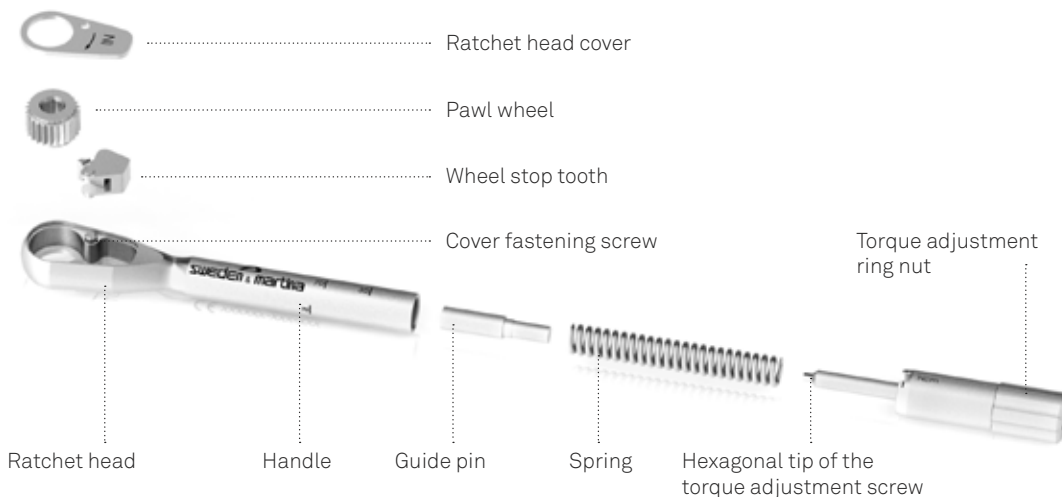

Before each use, this instrument must be cleaned and sterilized according to the instructions on page 52. Adequate maintenance, carried out by scrupulously following all the steps indicated for dismantling and reassembly of the torque wrench during cleaning operations is essential for its correct use and to prolong its shelf life. Personnel who use this tool must be suitably trained, and they must have read the instructions in this manual prior to handling the device.

After sterilisation, the key is ready for use. The instrument must be tested for correct assembly and correct functionality every time it is used, whether for surgical and prosthetic procedures.

The torque is adjusted by aligning the marking of the desired torque in the circular opening of the handle. The "IN" arrow legible on the top of the head indicates the screwing position of the key. The "OUT" arrow legible on the top of the head indicates the loosening or unscrewing position. An unlimited torque position is obtained by positioning the torque adjustment device up to the line marked "R" on the handle of the ratchet body.



The ring nut may be screwed and unscrewed by hand, but to speed up these operations the kit also contains a driver that allows it to be turned quickly. Any deterioration of the screwing, insertion and torque mechanisms must be checked by personnel responsible for the use and maintenance of this dental instrument.

The pieces of this mechanism are not interchangeable; one piece from one key cannot be replaced by a piece from another key as each ratchet is calibrated INDIVIDUALLY. If a piece is lost, please return the instrument to Sweden & Martina for repair. No components for assembling the ratchet can be sold individually. Failure to follow the instructions provided may cause problems of maintenance and stability of the prosthesis.



Important warning

Torque is always adjusted by screwing in/unscrewing the sleeve at the end of the instrument handle. Torque must always be adjusted upwards, starting from a value lower than that required and tightening the adjustment sleeve in a clockwise direction until the desired value is reached. This means that if a torque value lower than that used previously is to be set, the adjustment sleeve must be slackened by two whole turns beneath the new torque value required, and then tightened again in a clockwise direction to the desired value.

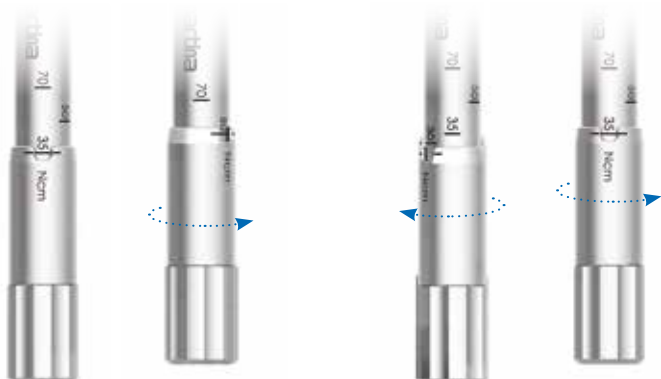

In order to set a torque value, turn the ring nut in the clockwise direction until the wanted value.

To turn down a torque value of work of the ratchet, first it is necessary to unscrew the ring nut in the anticlockwise senso until reaching a value inferior of the wanted one, then proceed with the clockwise direction screwing until the chosen torque.

Preparation of the implant site

During the software-assisted planning it is best as a rule to keep a distance of 3.00 mm between the perimeters of the implants and at least 2.00 mm between implants and adjacent natural teeth. Numerous clinical trials and experimental studies state that it is appropriate to position the implants more lingually or palately in order to obtain better esthetic results since such positioning helps to preserve the level of the soft and hard tissues coronally to the implant. It is also essential to check that the thickness of the residual osseous wall is not less than 1.00 mm. The best esthetic results are obtained with buccal walls of no less than 2.00 mm. The risk of bone resorption and exposure of the threads increases if thicknesses are thinner.

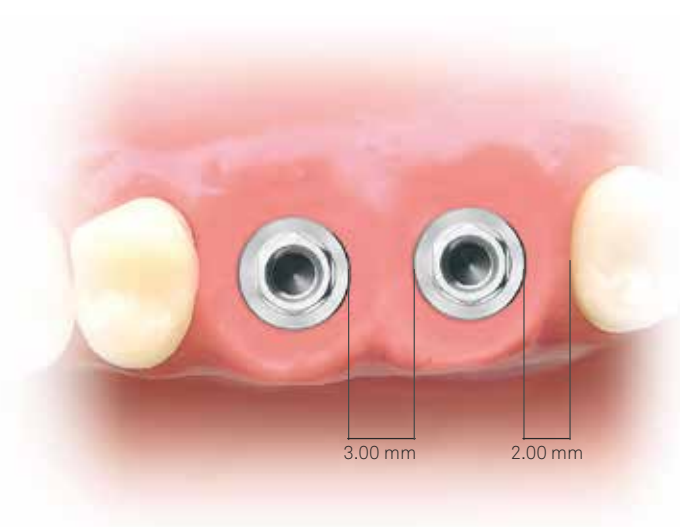

The appropriate preparation sequences for the Premium One and Prama implants are described in the following pages. These procedures have been developed through clinical experience and information from numerous clinical trials and protocols for implants with this endosseous morphology. However, it must always be taken into consideration that types of bone with different densities need different surgical approaches and the instructions that follow cannot and are not meant to substitute the required training, medical knowledge nor personal experience that sometimes suggests different indications. The sequences that follow, however, refer to specific bone types.

It should be borne in mind that standard drills always prepare a hole longer than the implant. Please see pages 24 and following for the dimensions of the overpreparation. The preparations must be atraumatic and the most gradual possible as well as be carried out quickly and accurately. The bone must not be overheated.

It should also be borne in mind that the surgical micromotor needs to be set to the correct torque, reduction and rotation values accordingly to the intervention that needs to be carried out.

In particular:

- **drills** must be used at the speed stated in each single sequence, with maximum torque and irrigated abundantly with cold sterile physiological solution, better if it has been cooled in a refrigerator;
- the **bone taps** must only be used when stated in the procedures.

Incorrect insertion of the instruments in the handpieces can lead to vibrations, eccentric rotation, precocious wear and bending of the shaft. It is recommended that only the surgical micromotors suitable to this application are used. It is also recommended that the micromotors are periodically checked by their manufacturer according to each individual instructions in order to prevent possible malfunctioning (e.g. movement of the transmission shaft axis, worn forceps, poor functioning, etc.). Not respecting the instructions provided can cause surgical problems and damage the patient's health.

The sequence for using the instruments in the kit is simple and intuitive. As explained on pages 44-45, it is mandatory the preliminary use of a mucotome (1), bone profiler (2) and initial drill (3) for the sleeve on the template. After that it is sufficient to identify on the surgical tray the height and diameter of the implant to be inserted (4) and use the 4 drills of the corresponding line in the white field for the \varnothing 4.15 mm sleeves (A) or in the black field for the \varnothing 5.50 mm sleeves (B). Whenever necessary, on completion of the preparation the countersink drill is used (5) and/or the bone tap (6) of the diameter of the implant to be inserted.

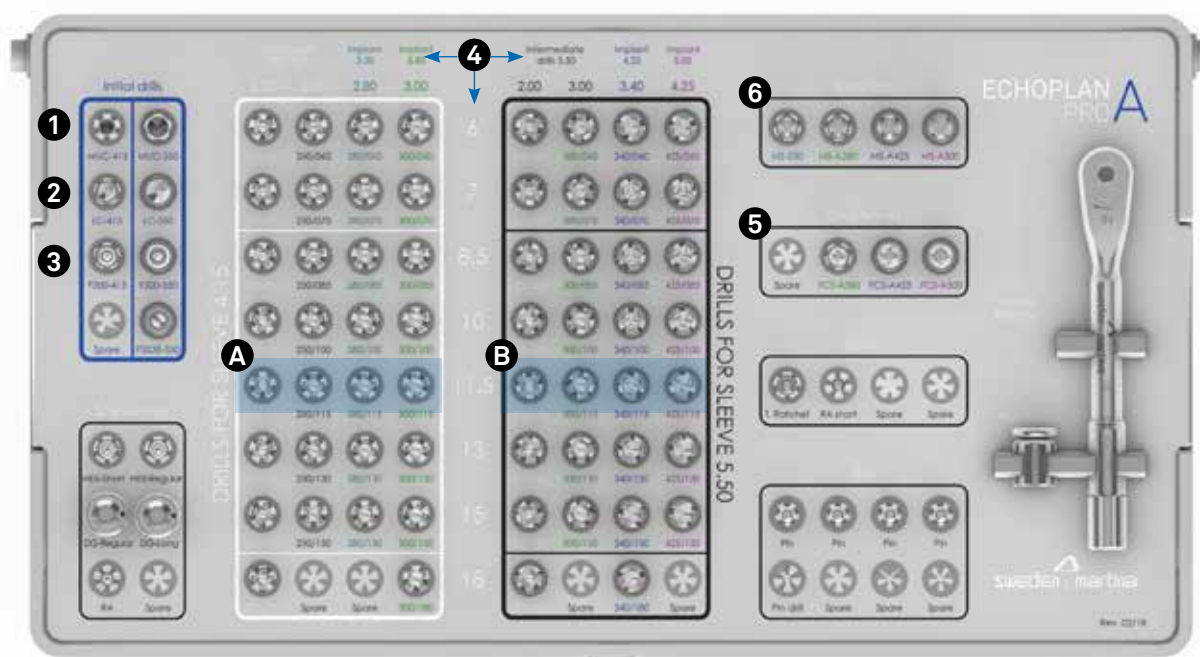

The following pages present these sequences subdivided by sleeve and diameter, **taking the insertion of an implant 11.50 mm in height (A-B)** as an example. It is simply a matter of changing the black field of the codes shown for all other heights with the height desired in order to have the correct sequence for the insertion of each implant length.

Surgical sequences - Premises

The initial phases of the insertion of any implant provide for the use of the following instruments in the order indicated:

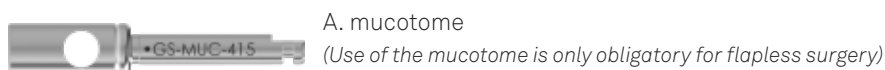

These first three steps must always be carried out before any other drill is used. Otherwise, correct guidance of the final drills cannot be guaranteed.

Important warning

The steps described below must always be taken before the final and/or intermediate drills are used. These steps must NEVER be skipped. The use of fewer surgical instruments could compromise a good result being obtained from the surgery. In fact, the correct guide of the final drills would not be guaranteed. Sweden & Martina advise that the drills should not be used for type D4 bone.

The sequences that follow refer to specific bone types.

However, it must always be taken into consideration that types of bone with different densities need different surgical approaches and the instructions that follow cannot and are not meant to substitute the training and medical knowledge required nor the personal experience that sometimes suggests different instructions.

The rotation speeds indicated must be respected.

It is not advised in both traditional and guided surgery to use rotating instruments in D4 quality bone. The use of osteotomes and/or bone compactors is preferable in order to conserve as much of the bone as possible (all of the instruments available are in the MC-IMP-PREMIUM-ONE-E and MC-IMP-PRAMA-E manuals which can be downloaded from Sweden & Martina's web site).

In this case only the obligatory stage can be guided up until the initial drill is used, which acts as a pilot hole for the osteotomes which not present integrated stops, must be used according to the traditional surgical protocols, that is, by removing the surgical template.

Preliminary surgical sequences

OBLIGATORY preliminary sequence for inserting the Premium One and Prama implants using the Echoplan PRO A kit, dedicated to guided implantology, in the case of a \varnothing 4.15 mm sleeve

Valid for implants:

Premium One: \varnothing 3.30, 3.80 mm

Prama: \varnothing 3.80 mm

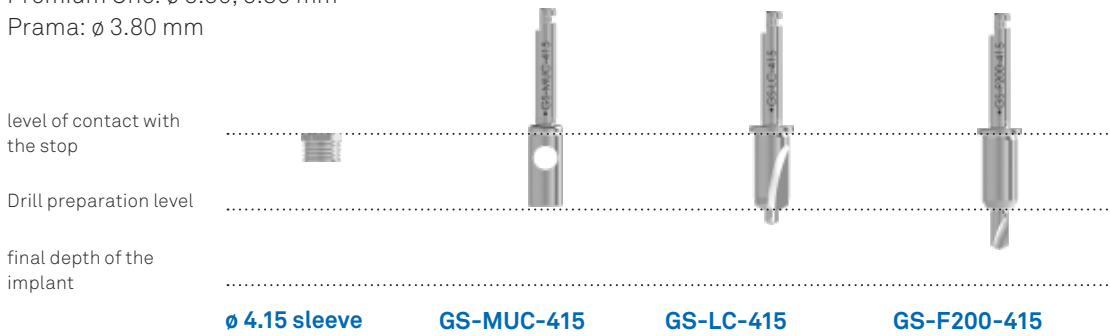

	work until contact with the bone	integrated stop	integrated stop
BONE D1	800 rpm	800 rpm	800 rpm
BONE D2	800 rpm	800 rpm	800 rpm
BONE D3	800 rpm	800 rpm	800 rpm
BONE D4	-	-	-

OBLIGATORY preliminary sequence for inserting the Premium One and Prama implants using the Echoplan PRO A kit, dedicated to guided implantology, in the case of a \varnothing 5.50 mm sleeve

Valid for implants:

Premium One: \varnothing 4.25, 5.00 mm

Prama: \varnothing 4.25, 5.00 mm

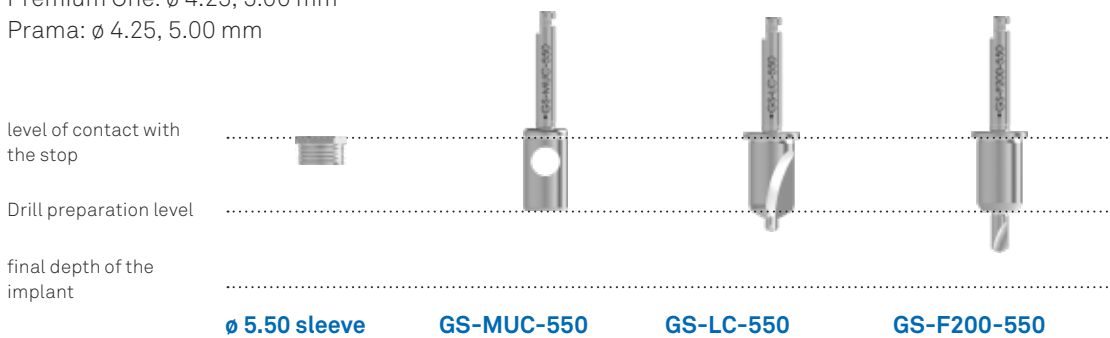

	work until contact with the bone	integrated stop	integrated stop
BONE D1	800 rpm	800 rpm	800 rpm
BONE D2	800 rpm	800 rpm	800 rpm
BONE D3	800 rpm	800 rpm	800 rpm
BONE D4	-	-	-

Important warning

The GS-F200-415 drill must not be used for the insertion of Syra Short implants with heights of 4.00 and 5.00 mm. Instead, use the appropriate drill specified in the sequences found on pages 60-63 and beyond.

Surgical sequences – \varnothing 4.15 mm sleeve

It should be borne in mind that drills overprepare the length for a measurement reported in the table on pages 24 and following. **The graphic sequence refers to the 11.50 mm high implants:** for all other heights, all that needs to be done is to replace the part with the code in black in the following table with the length of the implant.

Surgical sequence for \varnothing 3.30 mm Premium One implants

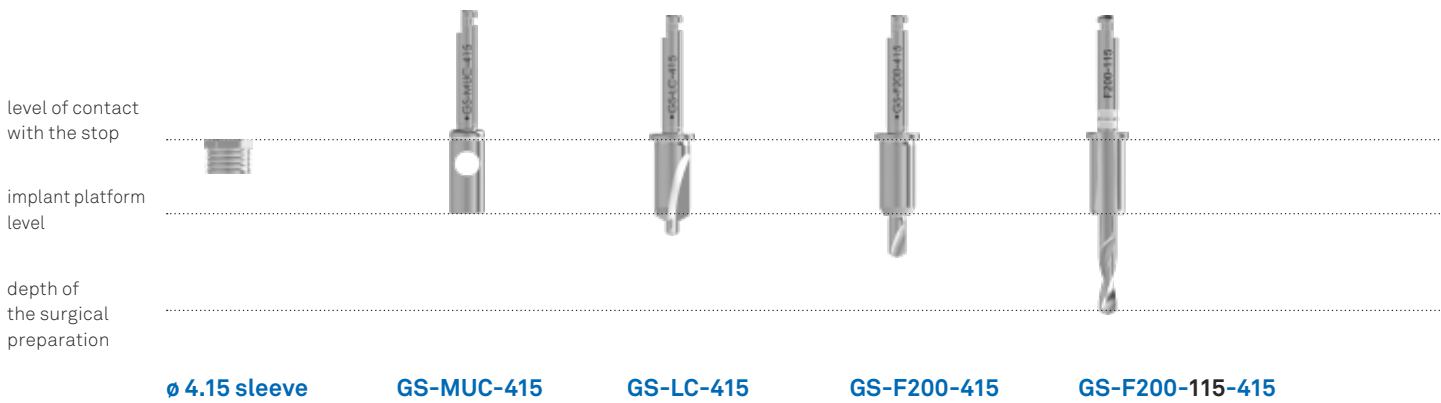

		\varnothing 4.15 sleeve	GS-MUC-415	GS-LC-415	GS-F200-415	GS-F200-115-415
\varnothing 3.30 mm	BONE D1		800 rpm	800 rpm	800 rpm	800 rpm
	BONE D2		800 rpm	800 rpm	800 rpm	800 rpm
	BONE D3		800 rpm	800 rpm	800 rpm	800 rpm
	BONE D4		-	-	-	-

Surgical sequence for \varnothing 3.80 mm Premium One implants

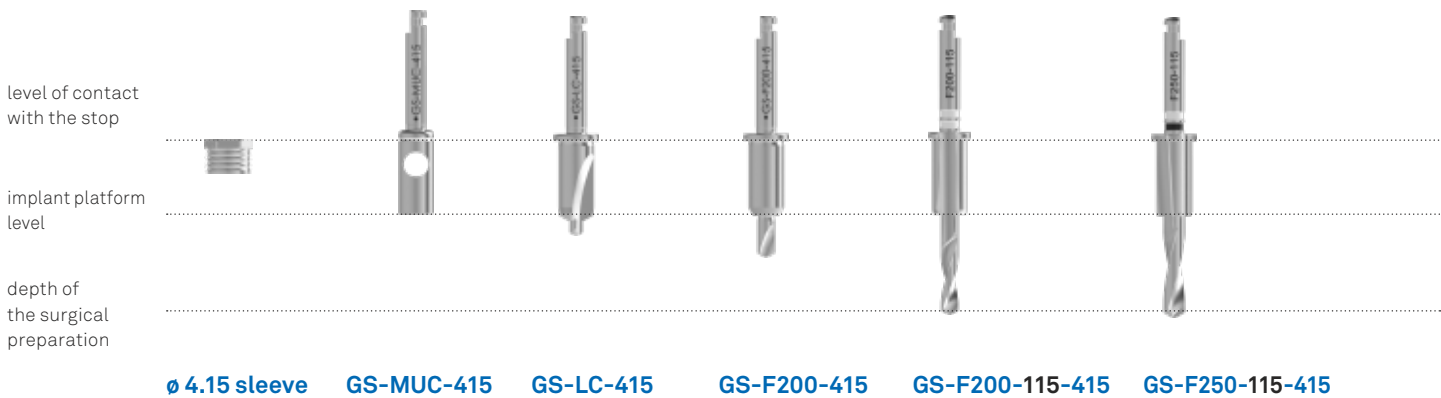

		\varnothing 4.15 sleeve	GS-MUC-415	GS-LC-415	GS-F200-415	GS-F200-115-415	GS-F250-115-415
\varnothing 3.80 mm	BONE D1		800 rpm	800 rpm	800 rpm	800 rpm	800 rpm
	BONE D2		800 rpm	800 rpm	800 rpm	800 rpm	800 rpm
	BONE D3		800 rpm	800 rpm	800 rpm	800 rpm	800 rpm
	BONE D4		-	-	-	-	-

Important warning

To insert implants more than 11.50 mm in height, it may be useful to carry out the intermediate phases including using the 8.50 mm or 10.00 mm drills so that the longer corresponding drills find space enough to get in contact with the sleeve through the integrated stop and so be guided for all of their use.

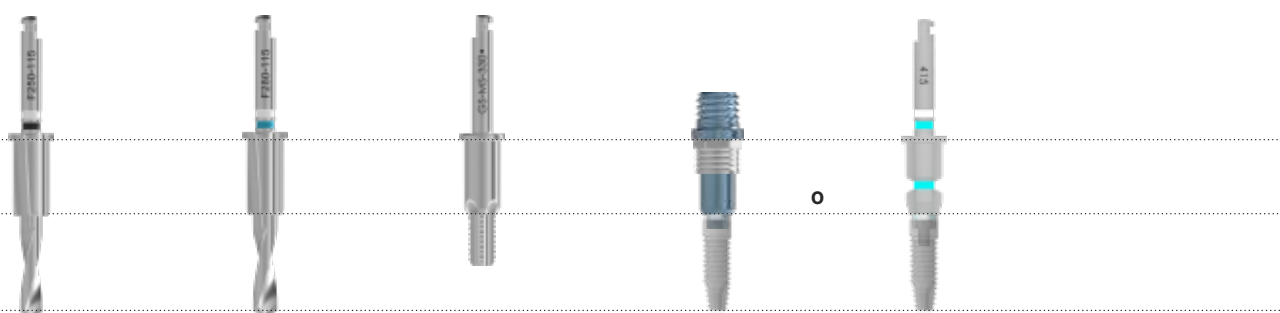

GS-F250-115-415 GS-F280-115-415 GS-MS-330 GS-MOU-A330 GS-EASY-AS-415-CA

		max 50 Ncm	max 50 Ncm	max 50 Ncm
800 rpm	800 rpm	20 rpm	20 rpm	20 rpm
800 rpm	800 rpm	-	20 rpm	20 rpm
800 rpm	800 rpm	-	20 rpm	20 rpm
-	-	-	-	-

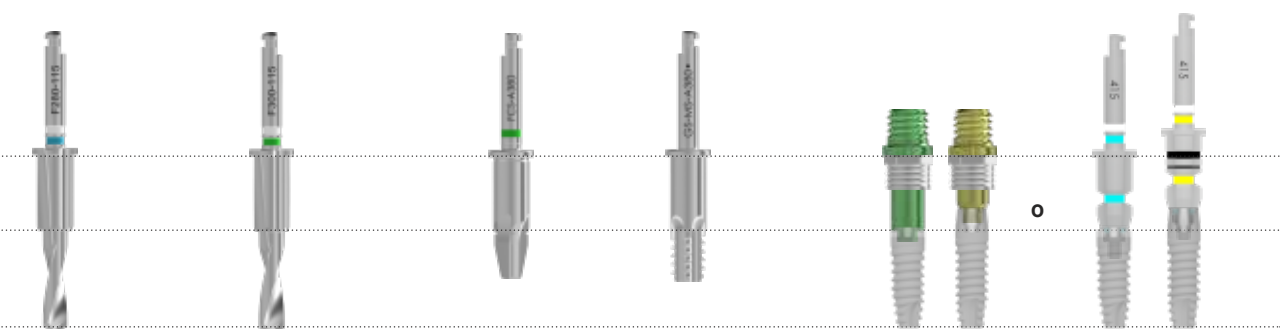

GS-F280-115-415 GS-F300-115-415 GS-FCS-A380 GS-MS-A380 GS-MOU-A380 GS-MOU-L415 GS-EASY-AS-415-CA GS-EASY-L-415-CA

	max 50 Ncm	max 50 Ncm	max 50 Ncm	max 50 Ncm	max 50 Ncm
800 rpm	20 rpm	20 rpm	20 rpm	20 rpm	20 rpm
800 rpm	-	20 rpm	20 rpm	20 rpm	20 rpm
800 rpm	-	20 rpm	20 rpm	20 rpm	20 rpm
-	-	-	-	-	-

Surgical sequences – \varnothing 5.50 mm sleeve

It should be borne in mind that the drills overprepare the length for a measurement reported in the table on pages 24 and following. **The graphic sequence refers to the 11.50 mm high implants:** in order to obtain the correct sequence of instruments to be used for all of other heights, all that needs to be done is substitute the length of the implant with the part with the code in black in the following table.

Surgical sequence for \varnothing 4.25 mm Premium One implants

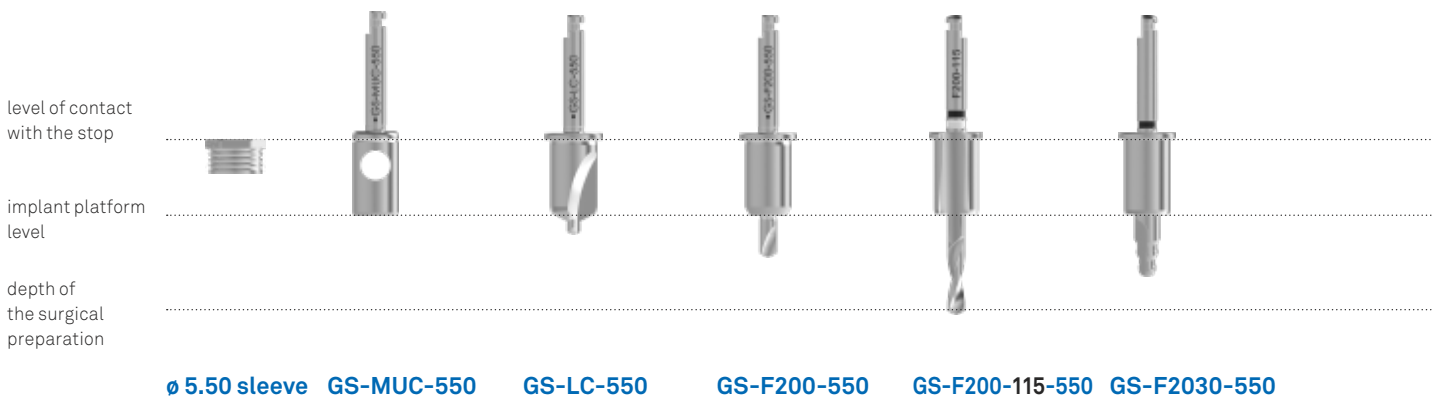

\varnothing 4.25 mm	BONE D1	800 rpm	800 rpm	800 rpm	800 rpm	800 rpm
	BONE D2	800 rpm	800 rpm	800 rpm	800 rpm	800 rpm
	BONE D3	800 rpm	800 rpm	800 rpm	800 rpm	800 rpm
	BONE D4	-	-	-	-	-

Surgical sequence for \varnothing 5.00 mm Premium One implants

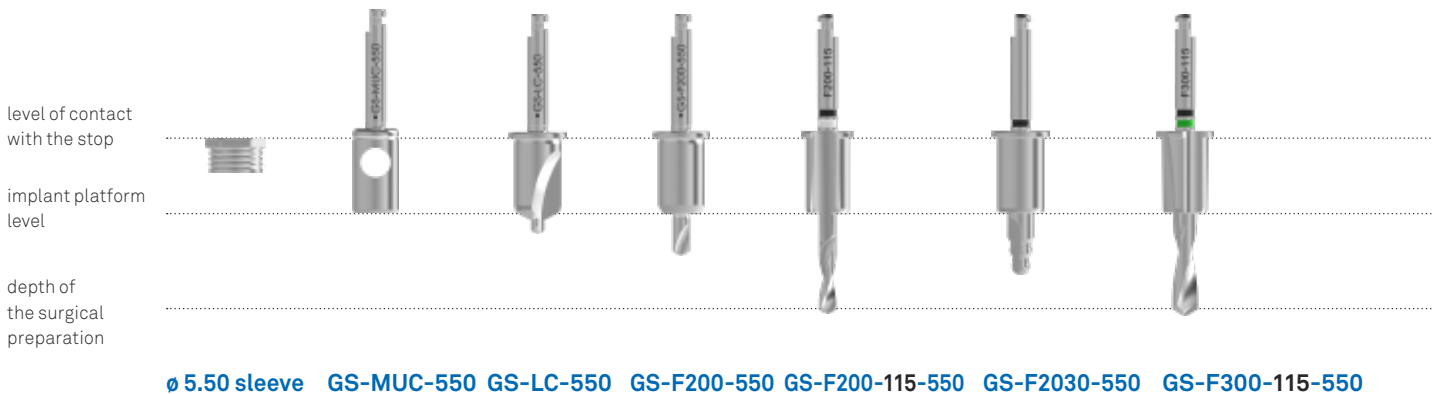

\varnothing 5.00 mm	BONE D1	800 rpm	800 rpm	800 rpm	800 rpm	800 rpm
	BONE D2	800 rpm	800 rpm	800 rpm	800 rpm	800 rpm
	BONE D3	800 rpm	800 rpm	800 rpm	800 rpm	800 rpm
	BONE D4	-	-	-	-	-

Important warning

To insert implants more than 11.50 mm in height, it may be useful to carry out the intermediate phases including using 8.50 mm or 10.00 mm drills so that the longer corresponding drills have space to use the sleeve with the integrated stop and so be guided for all of their use.

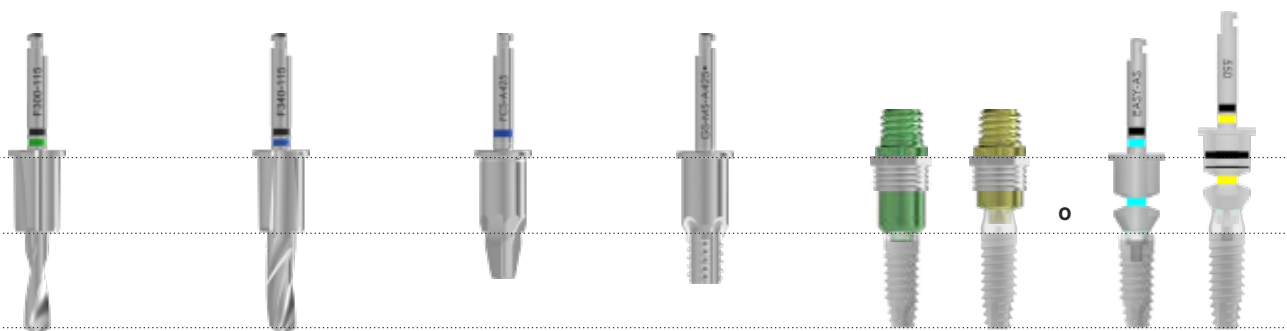

GS-F300-115-550 GS-F340-115-550 GS-FCS-A425 GS-MS-A425 GS-MOU-A380SP GS-EASY-AS-550-CA
GS-MOU-L550 GS-EASY-L-550-CA

			max 50 Ncm	max 50 Ncm	max 50 Ncm
800 rpm	800 rpm	800 rpm	20 rpm	20 rpm	20 rpm
800 rpm	800 rpm	800 rpm	-	20 rpm	20 rpm
800 rpm	800 rpm	800 rpm	-	20 rpm	20 rpm
-	-	-	-	-	-

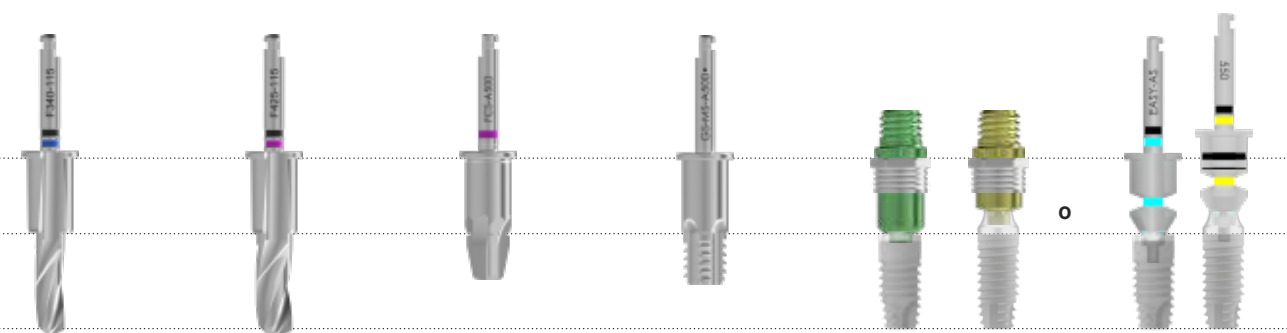

GS-F340-115-550 GS-F425-115-550 GS-FCS-A500 GS-MS-A500 GS-MOU-A380SP GS-EASY-AS-550-CA
GS-MOU-L550 GS-EASY-L-550-CA

			max 50 Ncm	max 50 Ncm	max 50 Ncm
800 rpm	800 rpm	800 rpm	20 rpm	20 rpm	20 rpm
800 rpm	800 rpm	800 rpm	-	20 rpm	20 rpm
800 rpm	800 rpm	800 rpm	-	20 rpm	20 rpm
-	-	-	-	-	-

Surgical sequences – 18.00 mm height implants

Since the 18.00 mm high implants have a insertion protocol that differs slightly from the logic just explained, the sequence is described in details for greater clarity. It should be borne in mind that drills overprepare the length as per specific measurements reported in the tables on pages 24-25.

Surgical sequence for 18.00 mm high ϕ 3.80 mm Premium One implants

	ϕ 4.15 sleeve	GS-MUC-415	GS-LC-415	GS-F200-415	GS-F200-180-415
ϕ 3.80 mm	BONE D1	800 rpm	800 rpm	800 rpm	800 rpm
	BONE D2	800 rpm	800 rpm	800 rpm	800 rpm
	BONE D3	800 rpm	800 rpm	800 rpm	800 rpm
	BONE D4	-	-	-	-

Surgical sequence for 18.00 mm high ϕ 4.25 mm Premium One implants

	ϕ 5.50 sleeve	GS-MUC-550	GS-LC-550	GS-F200-550	GS-F200-180-550
ϕ 4.25 mm	BONE D1	800 rpm	800 rpm	800 rpm	800 rpm
	BONE D2	800 rpm	800 rpm	800 rpm	800 rpm
	BONE D3	800 rpm	800 rpm	800 rpm	800 rpm
	BONE D4	-	-	-	-

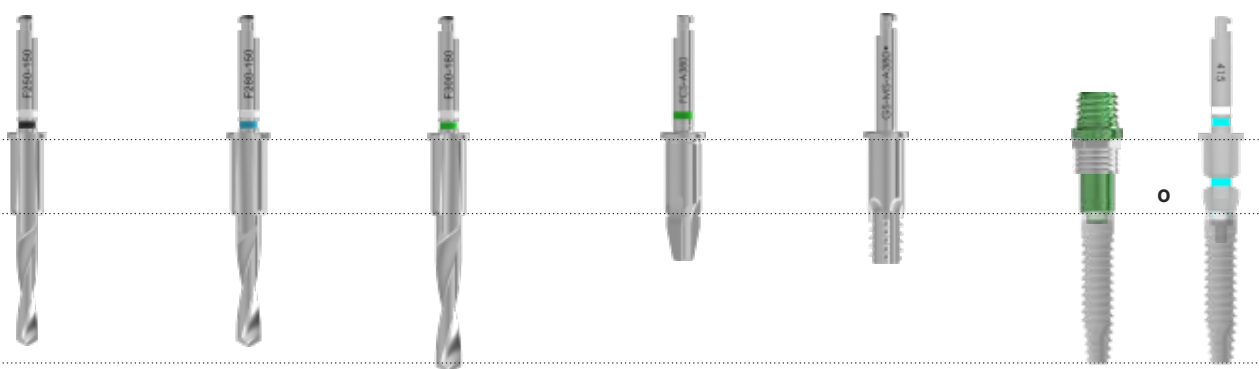

**GS-F250-150-415 GS-F280-150-415 GS-F300-180-415 GS-FCS-A380 GS-MS-A380 GS-MOU-A380
GS-EASY-AS-415-CA**

				max 50 Ncm	max 50 Ncm
800 rpm	800 rpm	800 rpm	800 rpm	20 rpm	20 rpm
800 rpm	800 rpm	800 rpm	800 rpm	-	20 rpm
800 rpm	800 rpm	800 rpm	800 rpm	-	20 rpm
-	-	-	-	-	-

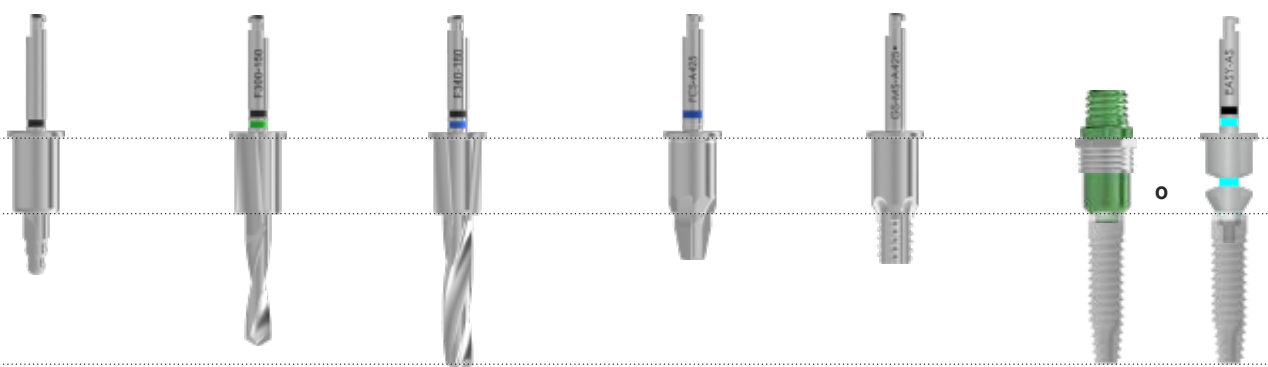

**GS-F2030-550 GS-F300-150-550 GS-F340-180-550 GS-FCS-A425 GS-MS-A425 GS-MOU-A380SP
GS-EASY-AS-550-CA**

				max 50 Ncm	max 50 Ncm
800 rpm	800 rpm	800 rpm	800 rpm	20 rpm	20 rpm
800 rpm	800 rpm	800 rpm	800 rpm	-	20 rpm
800 rpm	800 rpm	800 rpm	800 rpm	-	20 rpm
-	-	-	-	-	-

Insertion of the implant

1 Use the patient use label found inside the pack for the patient's medical records and apply it to the Dental Card: this makes the recording of the patient's treatment plan simpler and helps trace the batch used.



2 Open the blister and place the vial contained in it on a sterile surface (a single-use towel or a sterile cloth) or insert in one of the appropriate Mounter Organizer compartments, also previously sterilized, near the operating field.



3 Immediately before the insertion into the oral cavity, remove the blue cap of the vial, making sure not to remove the transparent cap containing the surgical cover screw. The implant holding cylinder inside the vial and the surgical cover screw are coloured according to a colour code that allows the rapid identification of the implant diameter.



(A) Open the small vial containing the implant (in the example a Premium One (code A-ZT-380-130) and assemble the mounter (code GS-MOU-A380) on to the implant itself using the appropriate screw (code GS-VTMOU-180, supplied with the mounter) and the screwdriver (code HSM-20-DG).

(B) Select the appropriate Easy Insert from those included in the kit and fit it by applying light manual pressure inside the mounter in order to extract the implant from the vial and transport it into the mouth. It should be borne in mind that the implant insertion must be carried out using the torque control so it is always advisable to complete the operation using the torque control ratchet and the Easy Insert with hexagon connection.

(C) After the unscrewing of the mounting screw, the mounter can be removed without tilting thanks to the GS-MOU-DG handpiece.

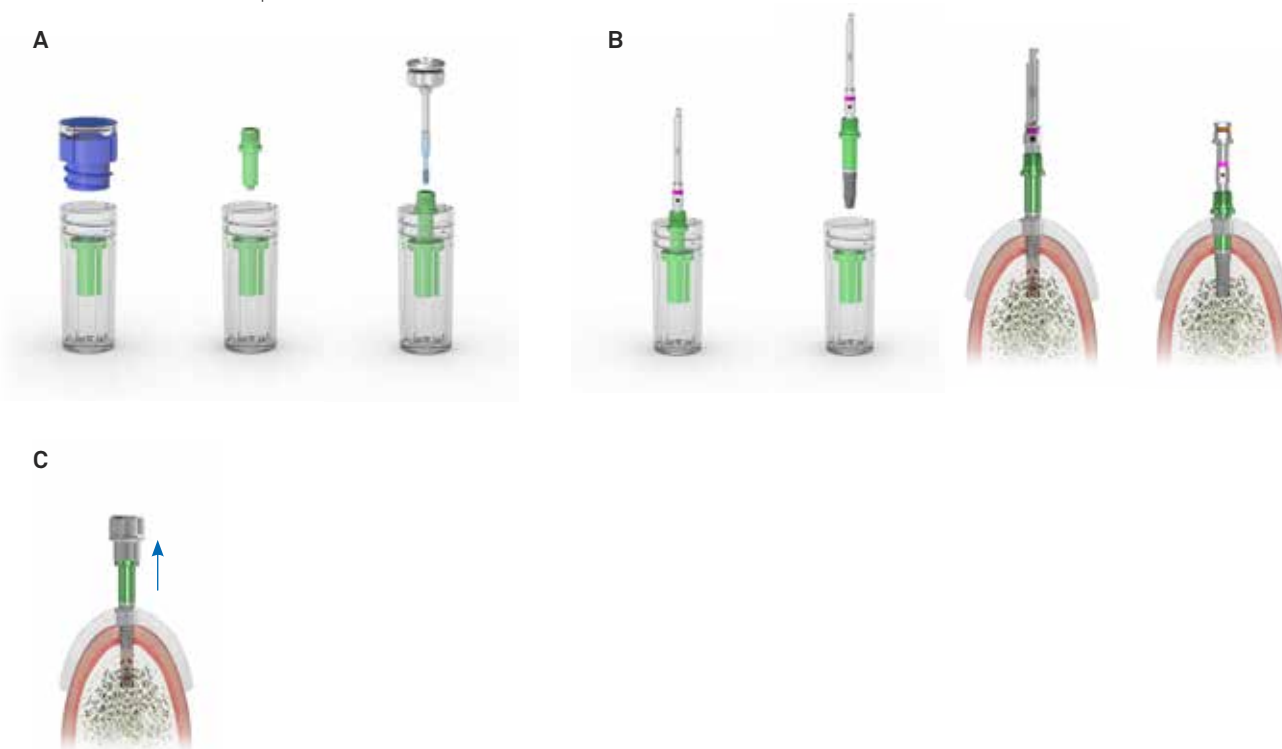

Phase after the implant insertion

Healing times

It is essential to respect the healing times recommended in implant surgery and periodically verify the progress of the osteointegration with X-rays. Preliminary healing times before loading an implant are influenced by the quality of the receiving bone.

Whenever it is decided to defer loading, in order to minimize the discomfort conditioned by respecting the biological time for osteointegration, temporary mobile prostheses must be used prudently, avoiding functional load of these mobile prostheses.

After healing, surgical cover screws are removed from the implants. After this, according to the protocol adopted, tissue profiles are adapted through an appropriate temporary restoration or using suitable healing abutments. It is recommended that healing screws are tightened using a torque of no more than 10 Ncm.

Cleaning, disinfection, sterilisation and storage of surgical kits and instruments

Warning! All surgical instruments for dental implants are sold in non-sterile condition. Before positioning in the oral cavity, the instruments must be cleaned, disinfected and sterilised according to the following procedure validated by Sweden & Martina.

These processes are to be performed before first use, and before each subsequent re-use.

Repeating the processes described in this section has a minimal effect on these devices' wear and tear.

Make sure to always check the functionality of the instruments before use. Any instrument showing signs of wear should be replaced with a new device immediately. Specifically, it is recommended that the correct retention of the screwdrivers inside the engagement wells on the heads of the screws that are to be taken out and screwed in with those tools always be checked. Failure to comply with these instructions may result in cross infection and intraoperative complications.

a.Cleaning

Containers and transport to be used for cleaning have no special requirements. If automated cleaning is applied: use ultrasonic bath with a suitable cleaning solution. It is recommended that only neutral detergents be used.

The concentration of the solution and the duration of the cleaning process should be in accordance with the solution manufacturer's instructions. Use demineralised water to prevent the formation of stains and marks.

When draining, check that residues have been completely removed from recesses, holes, etc., in the devices.

If necessary, repeat the cycle or clean manually.

If manual cleaning is performed, use a suitable neutral detergent, following the manufacturer's instructions for use. Brush the products with soft bristles under running water. Using the brush, apply the cleaning solution to all surfaces. Rinse with distilled water for at least 4 minutes.

Ensure that plenty of running water flows through any holes. When cleaning drills with internal irrigation, use the pins provided with the handpieces to ensure that the irrigation holes have been thoroughly cleaned and cleared of any residual bone chips or biological tissue. After rinsing, dry the devices completely and pack them in suitable sterilisation bags. If a drying cycle is performed as part of the washing and disinfection machine cycle, do not exceed 120 °C.

b.Sterilisation

When using a vacuum autoclave, sterilise using the following procedures:

- autoclave (Gravity-Displacement Cycles) at the temperature of 121 °C with a minimum of 30 minutes of exposure and a 15-minute drying cycle;
- autoclave (Dynamic-Air-Removal Cycles) at the temperature of 132 °C with 4 minutes of exposure and at least a 20-minute drying cycle.

c. Storage

After sterilisation, the product should remain in the pouches used for sterilisation. The pouches should only be opened immediately prior to reuse. Sterilisation pouches are normally capable of maintaining sterility inside the pouch unless the pouch is damaged. Care should therefore be taken to not use components if the pouches in which they were stored are damaged and to re-sterilise them in new pouches before use. The shelf life of sterilised products in pouches should not exceed that recommended by the pouch manufacturer. The product should be stored in a cool, dry place, away from direct sunlight, and from sources of water and heat.

Cleaning, disinfection, sterilisation and storage of the CRI5-KIT torque ratchet

The processes described below are to be carried out before the first use, and before any subsequent use. Repeating the processes described in this section has a minimal effect on these devices' wear and tear. Failure to comply with these instructions may result in cross infection. Containers and transport to be used for cleaning have no special requirements. As soon as possible after each use of the wrench, place it in a container filled with a disinfectant/detergent solution and cover everything with a cloth. The purpose of this operation is to prevent that contaminants from the patient dry out, by dissolving them, and to then make cleaning easier and more effective. Completely disassemble the wrench as indicated below.

Completely unscrew the torque adjustment screw and pull out the spring inside the ratchet body handle. Do not separate the spring from the pin that acts as a stop.

Using the hexagonal bit at the base of the torque adjustment screw, unscrew and completely remove the cover fastening screw from the side marked OUT. Apply light pressure to avoid damaging the hexagonal bit.

After removing the cover, remove the two components inside the ratchet head: the notched pawl wheel and the wheel stop tooth.



For manual cleaning, mechanically clean all of the tool's external and internal surfaces with a soft bristle brush under warm water. Rinse the poorly accessible holes in the head and around the pawl wheel and wheel stop tooth by injecting hot water using a syringe without the needle. If necessary, do the same for the inside of the handle and torque adjuster. Use a suitable neutral detergent, following the manufacturer's instructions for its use. Using the brush, apply the cleaning solution to all surfaces. Rinse with distilled water for at least 4 minutes. Make sure that plenty of running water flushes through all the passages. If automated cleaning is applied: use ultrasonic bath with a suitable cleaning solution.

It is recommended that only neutral detergents be used. The concentration of the solution and the duration of the cleaning process should be in accordance with the solution manufacturer's instructions. Use demineralised water to prevent the formation of stains and marks. During this cycle, avoid that the parts make contact with one another as this can cause deterioration of the machined surfaces, and a resulting loss of torque measurement accuracy. When draining, check that residues have been completely removed from recesses, holes, etc., in the devices. If necessary, repeat the cycle or clean manually.

Observation: Blood residues or other deposits reduce the effectiveness of sterilisation, which is why it is important to thoroughly clean all the parts. During all cleaning cycles, avoid that the liquids spurt or splash and work with appropriate personal protection. Avoid contact between this instrument and other nickel-plated instruments. The parts must be reassembled before sterilisation. Dry the parts and lubricate the functional areas moderately and reassemble the wrench as shown in the figures below. Excess lubricant will cause it to come up on the instrument's surface during sterilisation. Use only the lubricant supplied.

After having lubricated the parts shown in the figures, assemble the two elements that make up the ratchet head in the following sequence: toothed pawl wheel and then the wheel stop tooth.



Lubricate the areas that make contact between the pawl wheel tooth and the wheel stop tooth pin.



Once parts 2 and 3 have been lubricated and assembled in the ratchet head, position the cover and rotate the ratchet body from the OUT side. Tighten the screw with the hexagonal tip of the torque adjustment screw.



Lubricate the spring inside the ratchet handle as shown in the figure. Assemble the torque adjustment screw, checking that the instrument is working properly by manually activating the pawl wheel.



Sterilization: Before sterilisation, the wrench must be fully assembled and adjusted to its minimum torque. The medical device must undergo steam sterilisation.

Recommended cycle:

- 3 (4 for the US market) pre-vacuums,
- 18 minutes at 134°C / 273°F at 2 bars and drying for 20 minutes.

We recommend the use of devices fitted with vacuum pumps (type B) to reduce the risk of air pockets forming. This recommendation is particularly important for hollow tools and to guarantee perfect drying. The hot air steriliser is not recommended as it can accelerate the ageing of the spring and consequently cause modification of the torque.

This procedure is essential to maintain the precision of the instrument within a tolerance range of ± 3.5 Ncm. Operate the torque and insertion mechanism to check its correct operation.

Remove all traces of lubricant from the external surfaces of the key. Place the device in a suitable sterilization bag. Disassembly and reassembly operations must be carried out following the instructions provided.

Cleaning, disinfection, sterilization and storage of the TWL torque wrench

The TWL torque wrench and its screwdriver are produced by Elos Medtech Pinol A/S. For the cleaning, disinfection, sterilization and storage processes please refer to the producer's indications at the following link <https://elosmedtech.com/IFU/>

Cleaning/sterilisation/storage of prosthetic components

Warning! All surgical instruments for dental implants are sold in non-sterile condition. Before positioning in the oral cavity, the instruments must be cleaned, disinfected and sterilised according to the following procedure validated by Sweden & Martina.

Failure to comply with these instructions may result in cross infection and intraoperative complications.

a. Cleaning

Containers and transport to be used for cleaning have no special requirements. If automated cleaning is applied: use ultrasonic bath with a suitable cleaning solution. It is recommended that only neutral detergents be used.

The concentration of the solution and the duration of the cleaning process should be in accordance with the solution manufacturer's instructions. Use demineralised water to prevent the formation of stains and marks.

When draining, check that residues have been completely removed from recesses, holes, etc., in the devices.

If necessary, repeat the cycle or clean manually.

If manual cleaning is performed, use a suitable neutral detergent, following the manufacturer's instructions for use. Brush the products with soft bristles under running water. Using the brush, apply the cleaning solution to all surfaces. Rinse with distilled water for at least 4 minutes.

Ensure that plenty of running water flows through any holes. When cleaning drills with internal irrigation, use the pins provided with the handpieces to ensure that the irrigation holes have been thoroughly cleaned and cleared of any residual bone chips or biological tissue. After rinsing, dry the devices completely and pack them in suitable sterilisation bags. If a drying cycle is performed as part of the washing and disinfection machine cycle, do not exceed 120 °C.

b. Sterilisation

We recommend this vacuum procedure of sterilization with autoclave before use:

- autoclave (Gravity-Displacement Cycles) at the temperature of 121 °C with a minimum of 30 minutes of exposure and a 15-minute drying cycle;
- autoclave (Dynamic-Air-Removal Cycles) at the temperature of 132 °C with 4 minutes of exposure and at least a 20-minute drying cycle.

c. Storage

After sterilisation, the product should remain in the pouches used for sterilisation. The pouches should only be opened immediately prior to use. Sterilisation pouches are normally capable of maintaining sterility inside the pouch unless the pouch is damaged. Care should therefore be taken to not use components if the pouches in which they were stored are damaged and to re-sterilise them in new pouches before re-use. The shelf life of sterilised products in pouches should not exceed that recommended by the pouch manufacturer. The product should be stored in a cool, dry place, away from direct sunlight, and from sources of water and heat.

Please visit the website https://www.sweden-martina.com/en_gb/ifu/ for more information on:

- material composition;
- maintenance, cleaning/sterilization/storage of prosthetic components, surgical instrumentation and the
- CRI5-KIT torque control ratchet,
- legend of symbols used in packaging.

THE LAST REVISION DATE OF THIS MANUAL IS NOVEMBER 2022.

The design and manufacture of the devices covered by this manual has been undertaken in compliance with the most up-to-date directives and harmonised standards with regard to materials used, manufacturing processes, sterilisation, information provided and packaging.



rev.11-22



Sweden & Martina S.p.A.

Via Veneto, 10
35020 Due Carrare (PD), Italy
Tel. +39.049.9124300
Fax +39.049.9124290
info@sweden-martina.com

www.sweden-martina.com

Sweden & Martina Ltd

Unit 1b
Amberley Court, Whitworth Road
Crawley, West Sussex, RH11 7XL
Toll free 0800 1123575
info.uk@sweden-martina.com

Customer Service Digital Workflow

Tel. 08007747542
customerserviceDWF@sweden-martina.com

Sweden & Martina Inc.

Distributor for U.S.
info.us@sweden-martina.com

Sweden & Martina Mediterranea S.L. - España

info.es@sweden-martina.com

Sweden & Martina Lda - Portugal

info.pt@sweden-martina.com

The implants, standard prosthetic components and surgical instruments contained in this catalogue are Medical devices and are manufactured by Sweden & Martina S.p.A. They conform to the ISO 9001 and ISO 13485 standards and are certified with the CE marking, in compliance with Regulation (EU) Medical Devices no. 2017/745.

The Sweden & Martina plant manufactures Medical Devices in compliance with the CGMPs in force in the USA and in other countries worldwide.



Some products may not be regulatory/released for sale in all markets.

All trademarks herein are the property of Sweden & Martina S.p.A. unless otherwise indicated.

This material is intended for laboratories and clinicians and is not intended for patient distribution.

This material is not to be redistributed, duplicated, or disclosed without the express written consent of Sweden & Martina S.p.A.

For additional product information, including indications, contraindications, warnings, precautions, and potential adverse effects, see Sweden & Martina S.p.A. website.

The contents are updated at the time of publication. Check with the company for any subsequent updates.