

PRAMAPOWER

Catalogo





Sweden & Martina



Dental Arena



E Shop

PRAMA POWER

Indice

4	Prama Slim Power
6	Impianti Prama Power
14	Prama Power Nasal e Pterigoidei
16	UTM e ZirTi: due superfici in sinergia
19	I vantaggi della connessione unica Collex
20	Prama Power l'impianto per il flusso digitale completo
22	Ergonomia delle Procedure Chirurgiche
24	Kit chirurgico Prama Power
26	Kit chirurgici per la chirurgia guidata
30	Complementi per chirurgia guidata
32	Set integrativi opzionali
34	Strumenti chirurgici opzionali
38	Soluzioni protesiche d'eccellenza
39	Ricorso al foro vite angolato
40	Fase di impronta e modello
41	Transmucose di guarigione
42	Transmucose di guarigione Prama IN
43	Pilastrì provvisori
44	Pilastrì preformati
45	Pilastrì fresabili
45	Pilastrì calcinabili
46	Soluzioni con foro vite angolato
48	Linea protesica PAD ^e (Protesi Avvitata Disparallela Estetica)
50	Linea protesica PLAIN B-Space
51	Protesi conometrica Conico
52	Componenti per protesi digitale
58	Premilled
59	Soluzioni per overdenture
62	Viti protesiche cliniche e da laboratorio
63	Bibliografia

Prama Slim Power

SLIM \varnothing 3.30

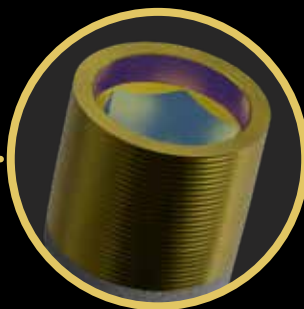

CONNESSIONE COLLEX

Per un approccio protesico semplificato

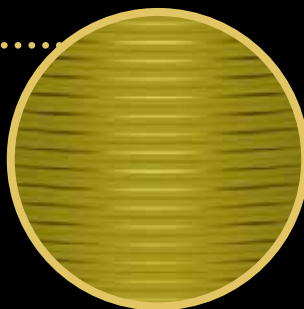

COLLO UTM

La superficie pensata per l'area di interfaccia tra tessuti molli e tessuti duri

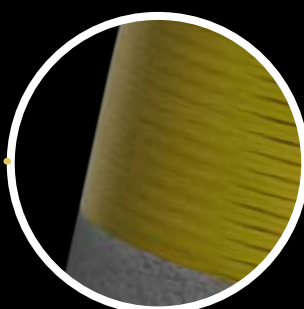

MORFOLOGIA CORONALE

Più stabile nelle corticali sottili



SPIRA REVERSE BUTTRESS

Tagliente e penetrante anche in osso duro



APICE

Rastremato, con spira più profonda per tutta la lunghezza, assicura stabilità soprattutto nei casi post-estrattivi

Impianti Prama Slim Power

∅ 3.30 mm



SHORT NECK h 1.80 mm

REGULAR NECK h 2.80 mm

h fixture	SHORT NECK h 1.80 mm	REGULAR NECK h 2.80 mm
6.00 mm	-	<p>∅ 3.30 ∅ 2.52 6.00 LAS-ZT-330-060</p>
8.50 mm	<p>∅ 3.30 ∅ 2.52 8.50 LAS-ZT-330-085</p>	<p>∅ 3.30 ∅ 2.52 8.50 LAS-ZT-330-085</p>
10.00 mm	<p>∅ 3.30 ∅ 2.52 10.00 LAS-ZT-330-100</p>	<p>∅ 3.30 ∅ 2.52 10.00 LAS-ZT-330-100</p>
11.50 mm	<p>∅ 3.30 ∅ 2.52 11.50 LAS-ZT-330-115</p>	<p>∅ 3.30 ∅ 2.52 11.50 LAS-ZT-330-115</p>
13.00 mm	<p>∅ 3.30 ∅ 2.52 13.00 LAS-ZT-330-130</p>	<p>∅ 3.30 ∅ 2.52 13.00 LAS-ZT-330-130</p>
15.00 mm	-	<p>∅ 3.30 ∅ 2.52 15.00 LAS-ZT-330-150</p>
vite chirurgica di chiusura (inclusa)	<p>L-VT-340</p>	

Impianti Prama Power

PRAMA POWER

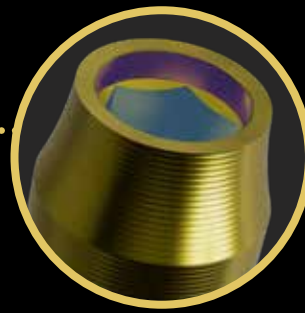

CONNESSIONE COLLEX
Comune a tutti i diametri per un approccio protesico semplificato

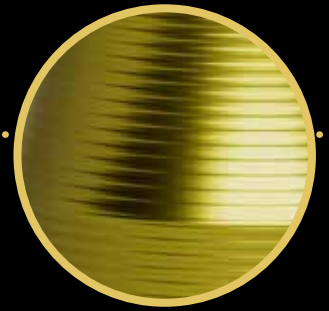

COLLO UTM
La superficie pensata per l'area di interfaccia tra tessuti molli e tessuti duri

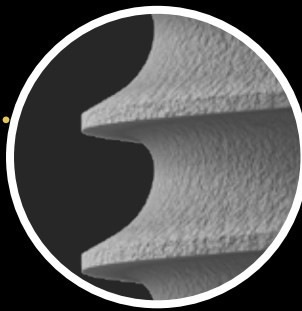

SPIRA REVERSE BUTTRESS
Tagliente e penetrante anche in osso duro

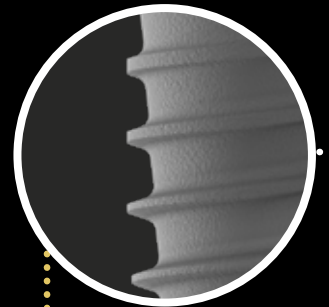

CORE CONICO E SPIRA CONICA
Consente un'ottima sensibilità durante l'inserimento

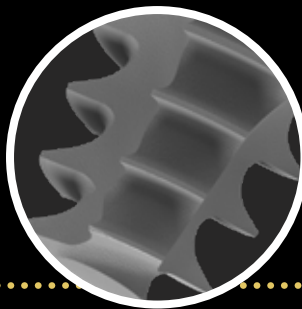

FRESATE APICALI
Studiate per facilitare l'inserimento e per la decompressione del coagulo

APICE
Rastremato, con spira più profonda per tutta la lunghezza, assicura stabilità soprattutto nei casi post-estrattivi



PRAMA RF POWER - PRAMA RF SL POWER

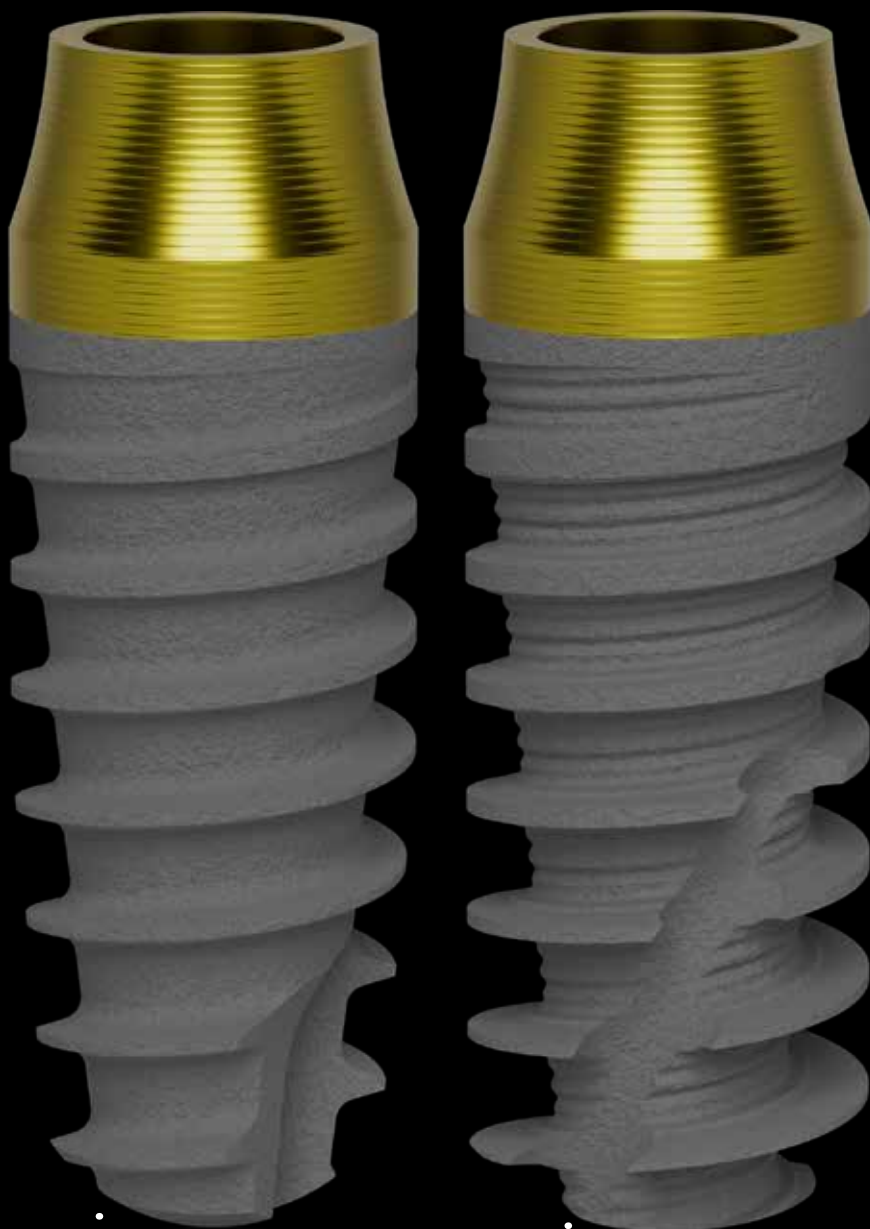

SPIRA LARGA E SCANALATURE NEL CORE

Per una maggiore stabilità primaria e per aumentare la superficie di contatto quando l'osso è meno denso

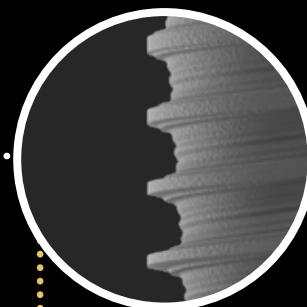

FILETTATURA

A ispessimento progressivo per aumentare la condensazione dell'osso scarsamente mineralizzato

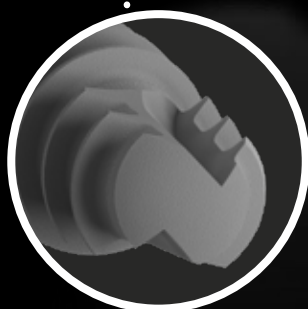

APICE

arrotondato perfetto per i rialzi di seno



TACCA APICALE

ELICOIDALE

Short Neck h 1.80 mm



PRAMA POWER		
h fixture	ø 3.80 ●	ø 4.25 ●
8.50 mm	<p>ø 3.80 ø 2.75 8.50 LAS-ZT-380-085</p>	<p>ø 4.25 ø 2.90 8.50 LAS-ZT-425-085</p>
10.00 mm	<p>ø 3.80 ø 2.75 10.00 LAS-ZT-380-100</p>	<p>ø 4.25 ø 2.90 10.00 LAS-ZT-425-100</p>
11.50 mm	<p>ø 3.80 ø 2.75 11.50 LAS-ZT-380-115</p>	<p>ø 4.25 ø 2.90 11.50 LAS-ZT-425-115</p>
13.00 mm	<p>ø 3.80 ø 2.75 13.00 LAS-ZT-380-130</p>	<p>ø 4.25 ø 2.90 13.00 LAS-ZT-425-130</p>
vite chirurgica di chiusura (inclusa)	<p>L-VT-340</p>	



PRAMA RF POWER

ø 3.80 ●

ø 4.25 ●



LSS-ZT-380-085



LSS-ZT-425-085



LSS-ZT-380-100



LSS-ZT-425-100



LSS-ZT-380-115













LSS-ZT-425-115

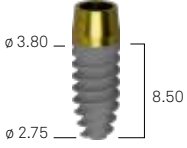
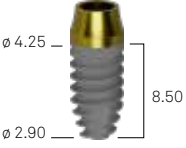
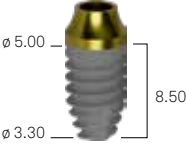

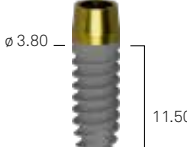
L-VT-340

Regular Neck h 2.80 mm

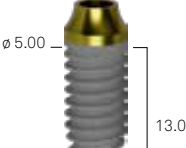

PRAMA POWER			
h fixture	ø 3.80 ●	ø 4.25 ●	ø 5.00 ●
6.00 mm	 <p>LA-ZT-380-060</p>	 <p>LA-ZT-425-060</p>	 <p>LA-ZT-500-060</p>
8.50 mm	 <p>LA-ZT-380-085</p>	 <p>LA-ZT-425-085</p>	 <p>LA-ZT-500-085</p>
10.00 mm	 <p>LA-ZT-380-100</p>	 <p>LA-ZT-425-100</p>	 <p>LA-ZT-500-100</p>
11.50 mm	 <p>LA-ZT-380-115</p>	 <p>LA-ZT-425-115</p>	 <p>LA-ZT-500-115</p>
13.00 mm	 <p>LA-ZT-380-130</p>	 <p>LA-ZT-425-130</p>	 <p>LA-ZT-500-130</p>
15.00 mm	 <p>LA-ZT-380-150</p>	 <p>LA-ZT-425-150</p>	-
vite chirurgica di chiusura (inclusa)	 <p>L-VT-340</p>		



PRAMA RF POWER

PRAMA RF SL POWER

ø 3.80 ●

ø 4.25 ●

ø 5.00 ●

ø 3.80 ●

ø 4.25 ●

ø 5.00 ●

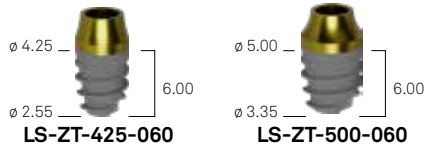

L-VT-340

Long Neck h 3.80 mm



PRAMA POWER

h fixture	ø 3.80 ●	ø 4.25 ●
8.50 mm	<p>LAL-ZT-380-085</p>	<p>LAL-ZT-425-085</p>
10.00 mm	<p>LAL-ZT-380-100</p>	<p>LAL-ZT-425-100</p>
11.50 mm	<p>LAL-ZT-380-115</p>	<p>LAL-ZT-425-115</p>
13.00 mm	<p>LAL-ZT-380-130</p>	<p>LAL-ZT-425-130</p>
15.00 mm	-	-
vite chirurgica di chiusura (inclusa)	<p>L-VT-340</p>	



PRAMA RF POWER

PRAMA RF SL POWER

ø 3.80 ●

ø 4.25 ●

ø 3.80 ●

ø 4.25 ●



LSL-ZT-380-085



LSL-ZT-425-085



LSL-ZT-380SL-085



LSL-ZT-425SL-085



LSL-ZT-380-100



LSL-ZT-425-100



LSL-ZT-380SL-100



LSL-ZT-425SL-100

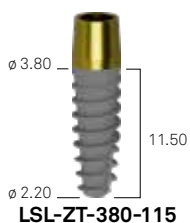

LSL-ZT-380-115



LSL-ZT-425-115



LSL-ZT-380SL-115



LSL-ZT-425SL-115

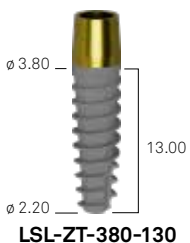

LSL-ZT-380-130



LSL-ZT-425-130

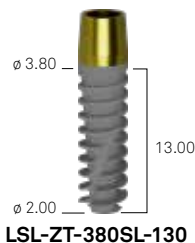

LSL-ZT-380SL-130



LSL-ZT-425SL-130

-

-

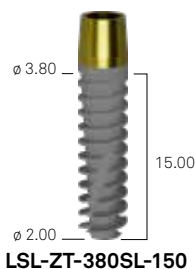

LSL-ZT-380SL-150

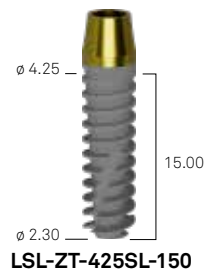

LSL-ZT-425SL-150



L-VT-340

PRAMA POWER NASAL E PTERIGOIDEI

In presenza di gravi atrofie, ci sono delle alternative alla rigenerazione ossea che possono aumentare la predicibilità del trattamento e consentire anche il carico immediato.

L'ampliamento della gamma Prama Power consente di sfruttare il posizionamento nasale e pterigoideo per aumentare la stabilità primaria e la resistenza biomeccanica dell'intera riabilitazione.

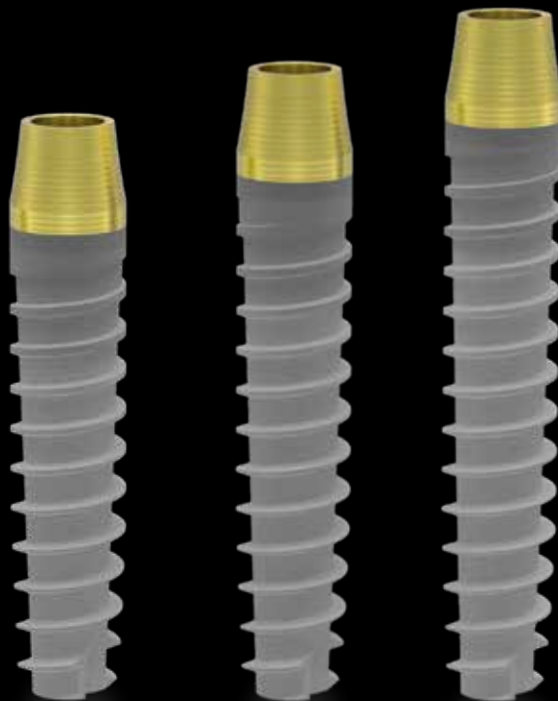

Queste tecniche, alla portata di molti implantologi medio-avanzati, si dimostrano semplici quando abbinare ad un serio studio prechirurgico che permetta di evidenziare l'osso da ingaggiare, l'inclinazione dell'impianto e le limitanti anatomiche.



Impianti Prama Power Nasal e Pterigoidei



	SHORT NECK 1.80 mm		REGULAR NECK 2.80 mm		LONG NECK 3.80 mm	
h fixture	ø 3.80 ●	ø 4.25 ●	ø 3.80 ●	ø 4.25 ●	ø 3.80 ●	ø 4.25 ●
18.00 mm	 LSS-ZT-380SL-180	 LSS-ZT-425SL-180	 LS-ZT-380SL-180	 LS-ZT-425SL-180	 LSL-ZT-380SL-180	 LSL-ZT-425SL-180
20.00 mm	 LSS-ZT-380SL-200	 LSS-ZT-425SL-200	-	-	 LSL-ZT-380SL-200	 LSL-ZT-425SL-200
22.00 mm	 LSS-ZT-380SL-220	 LSS-ZT-425SL-220	-	-	 LSL-ZT-380SL-220	 LSL-ZT-425SL-220
vite chirurgica di chiusura (inclusa)	 L-VT-340					

Lucidi radiografici Prama Power, Prama RF Power, Prama Power Nasal e Pterigoidei

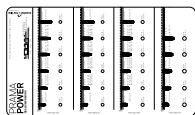

L-L100	dimensioni reali
L-L120	dimensioni maggiorate del 20%
L-L130	dimensioni maggiorate del 30%

Frese: Per inserire gli impianti Prama Power Nasal e Pterigoidei sono state realizzate delle frese dedicate, con i relativi stop, che permettono di preparare tutte le lunghezze implantari.

Frese			Stop di profondità
	FP-200-L-SW	Fresa pilota	STOP-2025-180-SW STOP-2025-190-SW STOP-2025-210-SW STOP-2025-220-SW
	FK250-L-SW	Fresa intermedia conica	STOP-2025-240-SW STOP-2025-260-SW
	FK380-L-SW	Fresa finale conica	STOP-3842-180-SW STOP-3842-190-SW STOP-3842-210-SW
	FK425-L-SW	Fresa finale conica	STOP-3842-220-SW STOP-3842-240-SW STOP-3842-260-SW

È disponibile opzionalmente un tray per alloggiare le frese e gli stop per impianti Nasal e Pterigoidei Power (cod. EXTR-26-TRAY-INT).
Non tutti i prodotti potrebbero essere disponibili per la vendita in tutti i mercati.

UTM e ZirTi: due superfici in sinergia

Superficie UTM: il substrato pensato per i tessuti molli

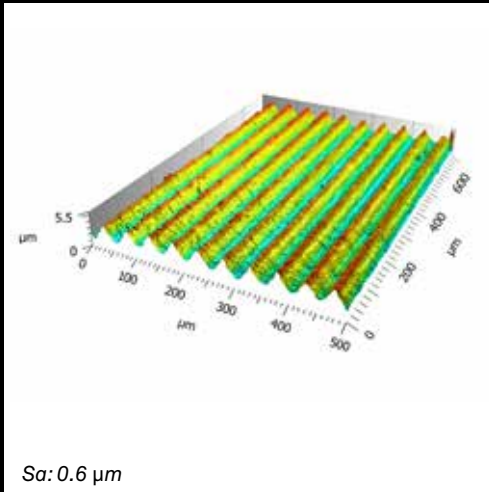

Non è una superficie macchinata, ma è una microfilettatura regolare che conferisce il dimensionamento corretto per potenziare l'organizzazione cellulare.



Immagine per gentile concessione prof. Macaluso, Università di Parma, Dipartimento di Medicina e Chirurgia - Centro di Odontoiatria.

Disposizione di fibroblasti sulla superficie UTM dopo 72 ore osservati con microscopia a fluorescenza.

La micro-rigatura presente sul collo implantare offre una guida per il movimento unidirezionale delle cellule, con il **beneficio biologico di una deposizione più rapida, organizzata ed orientata delle fibre collagene.**

Il conseguente beneficio clinico è un processo di **guarigione più veloce** e un mantenimento a lungo termine di **tessuti sani e stabili** nel tempo.

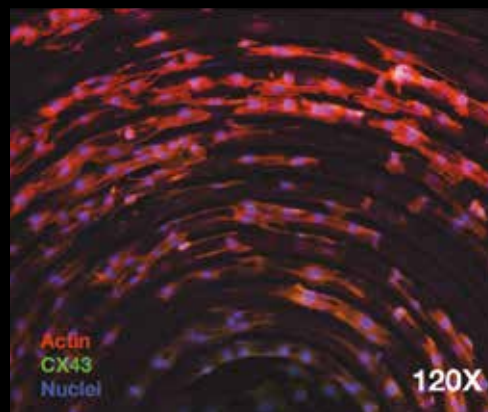
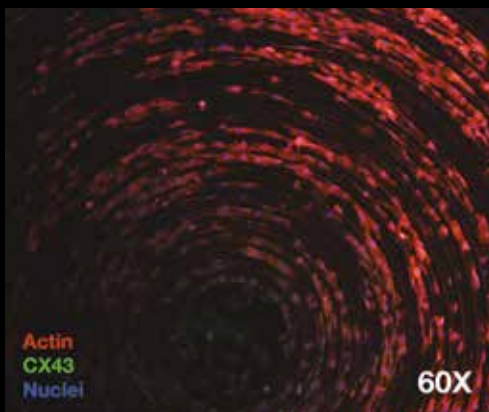
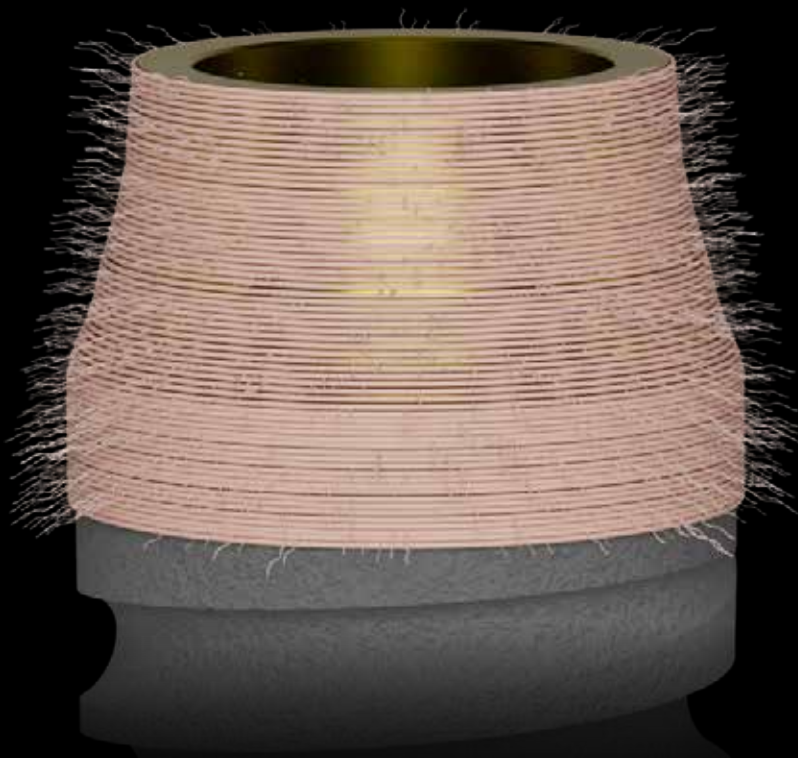

Convergenza e UTM

Maggior densità di fibre

CLINICAL
ORAL IMPLANTS
RESEARCH

Influence of abutment macro- and micro-geometry on morphologic and morphometric features of peri-implant connective tissue

L. Canullo, A. Giuliani, M. Furlani, M. Menini, A. Piattelli, G. Iezzi

Un rivoluzionario studio istologico in umano pubblicato sul Clinical Oral Implants Research, elaborato per mezzo di **tomografia al sincrotrone**, ha dimostrato che la **sinergia tra il profilo convergente della componente intramucosa e la superficie UTM migliora l'adesione e l'attivazione precoce dei fibroblasti**, favorendo la formazione di un sigillo biologico e promuovendo l'integrazione dei tessuti molli perimplantari. La **tomografia al sincrotrone**, insieme alla significativa differenza nell'altezza del tessuto connettivo (spessore verticale) tra gruppi convergenti e divergenti, ha anche evidenziato l'effetto significativamente positivo della **superficie microrigata 3D UTM (CONV-UTM)** rispetto a quella convergente macchinata (CONV-MAC) e, ancor più, rispetto a quella divergente (DIV-MAC) in termini di densità dei fasci di collagene che si intrecciano.

Microscopia a luce polarizzata della sezione longitudinale del tessuto molle intorno all'abutment convergente UTM. Il colore blu chiaro (freccette rosse) indica le fibre di collagene parallele al profilo verticale dell'unità impianto-abutment, mentre il colore blu scuro mostra le fibre di collagene che corrono perpendicolarmente o circolarmente all'unità impianto-abutment.

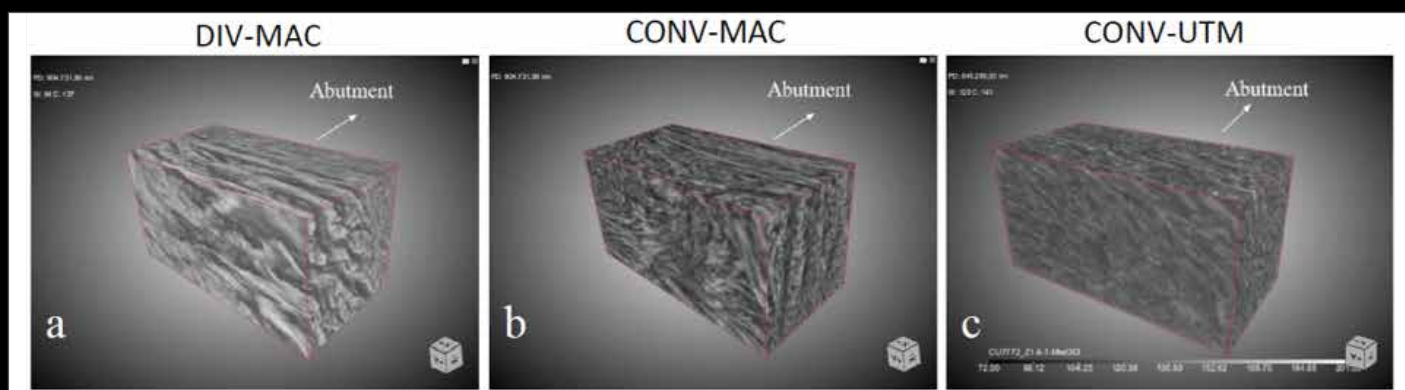

Lo studio ha dimostrato l'**effetto positivo** della macrogeometria della **morfologia convergente** rispetto alla **tradizionale geometria transmucosa divergente** in termini di densità fibre collagene. La geometria convergente della porzione implantoprotetica a contatto con i tessuti molli riveste un ruolo chiave nella qualità della guarigione perimplantare.

UTM e ZirTi: due superfici in sinergia

Superficie ZirTi: è l'ideale per l'osteointegrazione

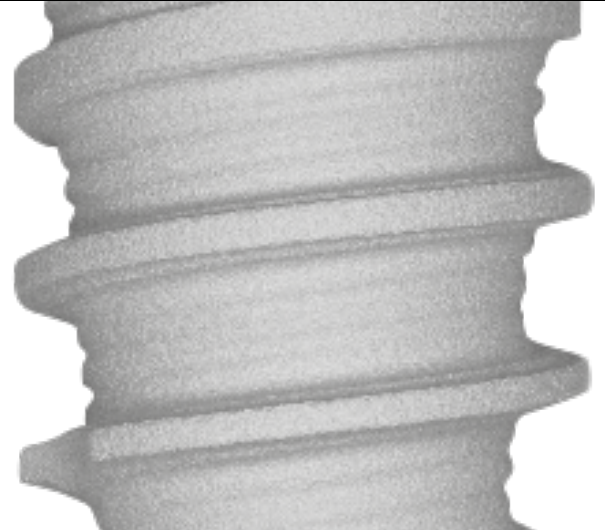
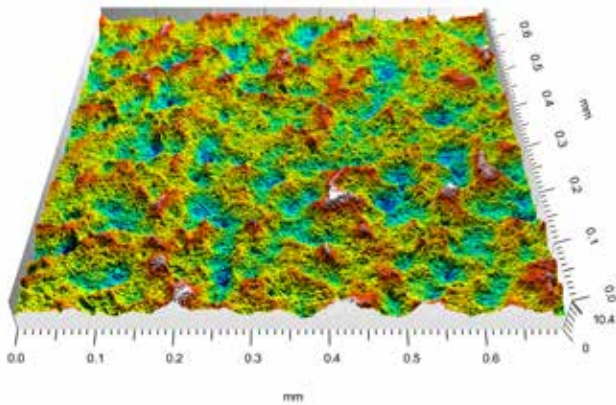

Sa: 1.4-1.7 μm

La superficie ZirTi è ottenuta con un processo con sabbatura con ossido di zirconio, seguito da una acidatura che conferisce una topografia a cui gli osteoblasti hanno dimostrato di adattarsi intimamente e di attivare una rapida proliferazione.

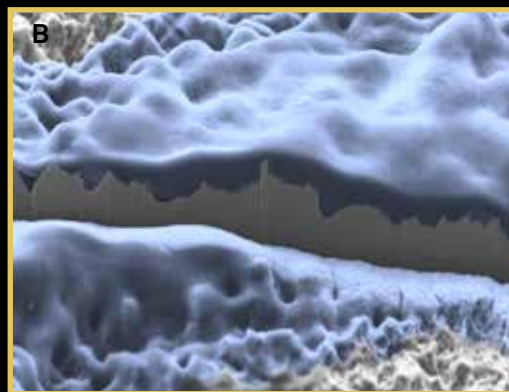
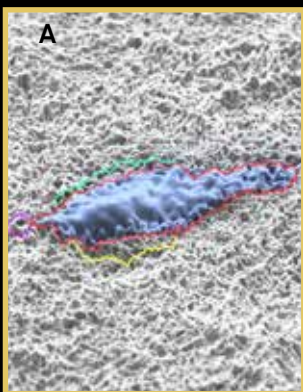

Ingrandimenti di osteoblasti primari sulla superficie ZirTi: nelle immagini A e B è visibile l'intimo adattamento di una cellula sui picchi che caratterizzano la ZirTi, grazie ad una sezione ottenuta con FIB (Focused Ion Beam).

Immagine per gentile concessione prof. Macaluso, Università di Parma, Dipartimento di Medicina e Chirurgia - Centro di Odontoiatria.

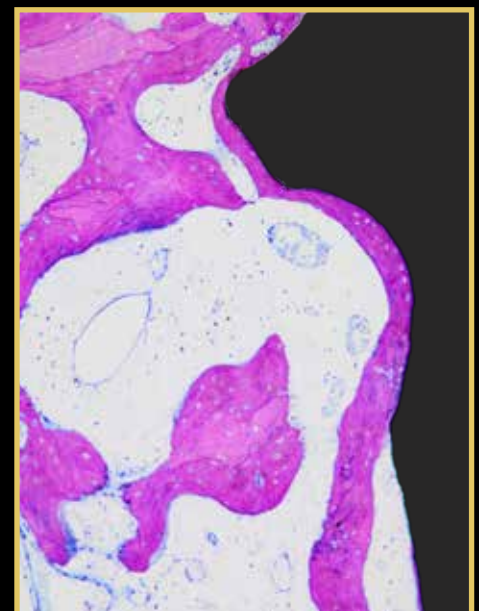

Istologia in umano a 3 mesi: anche in osso D4 si osserva un'ottima mineralizzazione a contatto con la superficie ZirTi.

Immagine per gentile concessione prof. M. Gargari, dott. A. Rocci.



Bibliografia sulla
superficie ZirTi

I vantaggi della CONNESSIONE UNICA COLLEX

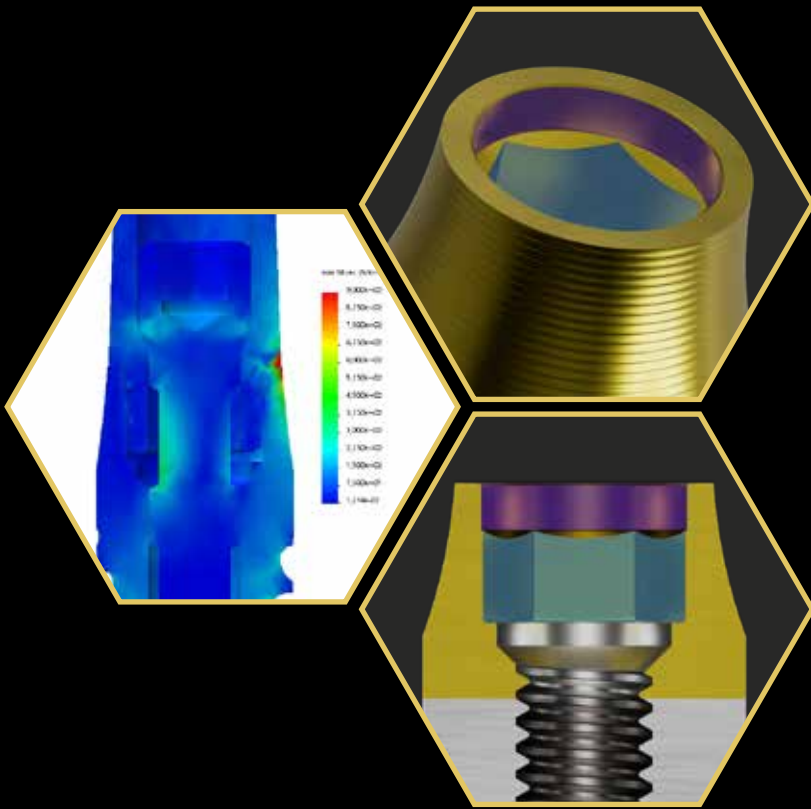

CONNESSIONE COLLEX:

vari studi ne hanno documentato robustezza e stabilità protesica rispetto ad altre connessioni senza collarino.



Bibliografia sulla
connessione Collex

Connessione ad **ESAGONO**

INTERNO con un collarino uguale per tutti i diametri.

QUATTRO DIVERSI DIAMETRI IMPLANTARI

accomunati da una
unica connessione.



Platform switching orizzontale e verticale STABILITÀ DEI TESSUTI

Da molti anni ormai la letteratura scientifica si occupa del concetto di **platform switching**, la tecnica di riabilitazione protesica che prevede l'utilizzo di abutment di diametro inferiore alla piattaforma implantare al fine di migliorare la distribuzione biomeccanica del carico protesico, ma soprattutto per distanziare la connessione protesica dall'osso cervicale allontanando dall'osso il punto critico di infiltrato batterico. È proprio da questa esperienza che nasce l'idea di **massimizzare con il collo Prama Power il platform switching, sfruttandone sia la componente orizzontale che quella verticale.**

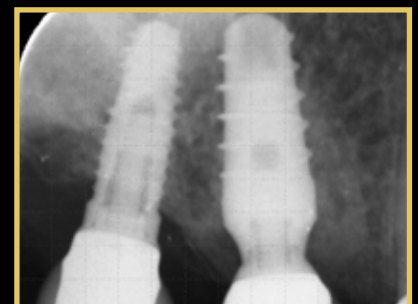

Courtesy of Dentisti Vignato

PRAMA POWER

L'IMPIANTO PER IL FLUSSO DIGITALE COMPLETO

Digital Atelier

Un unico team per tutti i servizi di:

- Progettazione;
- Produzione protesi custom made;
- Chirurgia guidata;
- Stampa 3D;
- Assistenza.



Courtesy of dr. Davide Di Paola



ACQUISIZIONE DATI



STAMPA 3D E
FRESAGGIO



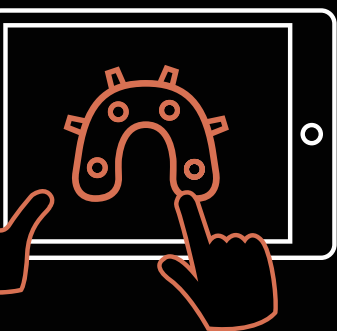

IMPLANTOLOGIA GUIDATA

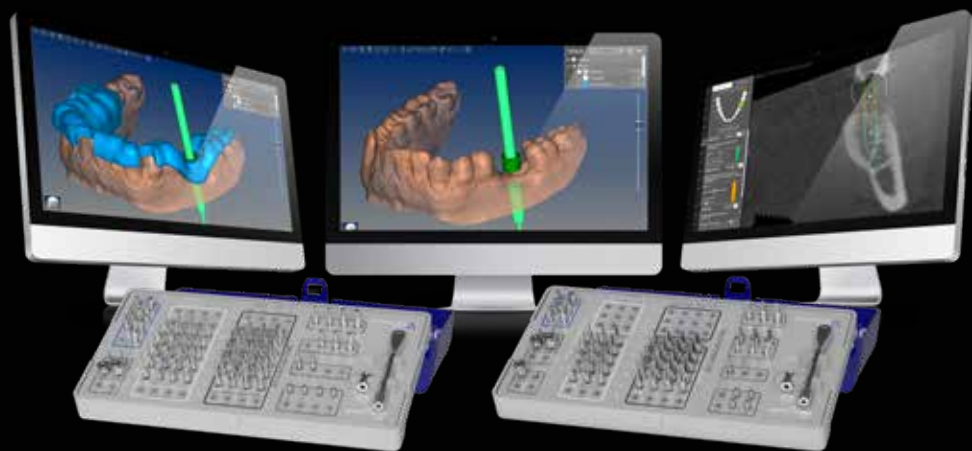

ECHOPLAN PRO A

ECHOPLAN PRO S

Implantologia Guidata

Con l'uso del software Archiplan è possibile realizzare le dime chirurgiche. La chirurgia guidata è resa particolarmente semplice grazie alla disponibilità di apposita strumentazione dedicata: kit chirurgici completi di frese, mucotomi, livellatori, driver, avvitatori e tutto il necessario per eseguire una chirurgia guidata con Prama Power.

Le frese con stop integrato permettono di risparmiare tempo e ottenere risultati predicibili. Per il dettaglio del contenuto dei kit per chirurgia guidata con cui inserire Prama Power si veda da pag. 26.



CAD-CAM

Protesi Custom Made

Il Digital Atelier può:

- scansionare i modelli fisici ricevuti dai clienti;
- acquisire modelli virtuali già scansionati intraoralmente o a banco dai clienti e inviati sotto forma di file, provenienti da tutti i sistemi di scanner aperti;
- modellare virtualmente qualsiasi manufatto protesico su prescrizione del cliente;
- produrre con tecnologia CAD CAM manufatti custom made.



Scarica le guide Exocad

Ergonomia delle Procedure Chirurgiche

I **KIT CHIRURGICI** sono **completi, compatti, ergonomici** e contengono tutti gli strumenti necessari per la chirurgia degli impianti **Prima Power**.

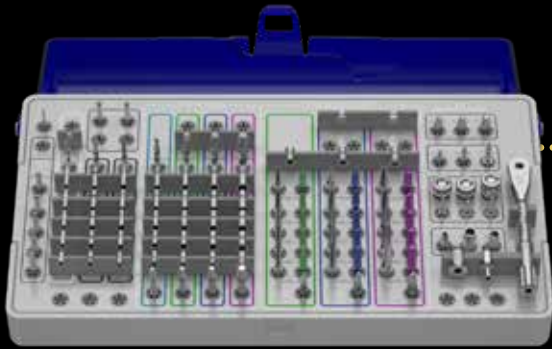

I codici colori, presenti anche sui tray chirurgici, guidano la corretta sequenza di utilizzo degli strumenti.



Sia le frese che gli stop sono caratterizzati da un codice colore che guida gli operatori nella scelta degli strumenti.



I **TRAY CHIRURGICI** sono realizzati in **Radel**, un polimero che non altera le proprie caratteristiche nemmeno dopo numerosi cicli di lavaggio e sterilizzazione in autoclave.

Le **FRESE CILINDRICHE** o **CONICHE** in funzione delle diverse preparazioni vengono fornite complete degli stop di profondità.

Le frese sono in **acciaio inossidabile** per uso chirurgico e mantengono inalterate le proprie caratteristiche per lungo tempo e molti utilizzi.



Le frese sono caratterizzate dalla presenza di **tacche di profondità** ben visibili.

Le frese sono **molto taglienti, centrate e performanti**. La morfologia delle frese coniche permette di raccogliere osso prezioso per le necessità di rigenerazione.





I Kit contengono un pratico **CRICCHETTO**, che può essere utilizzato sia come chiave fissa che come chiave dinamometrica utile per il controllo del torque di inserimento degli impianti e avvitamento delle viti protesiche.

- Il torque può essere regolato da 10 a 70 Ncm;
- La regolazione del torque è estremamente precisa perché ogni singolo cricchetto viene tarato individualmente.

In dotazione vi è una gamma di **AVVITATORI PROTESICI** molto ampia sia per uso digitale che con il cricchetto dinamometrico che con il micromotore.

La gamma è idonea alle diverse necessità di accesso al cavo orale, da strumenti extra corti a strumenti più lunghi per riabilitazioni protesiche di tipo Toronto.

L'accoppiamento leggermente conico tra avvitatore e vite consente una ritentività adeguata al trasporto in sicurezza di quest'ultima nel cavo orale.



La procedura chirurgica prevede un approccio mountless che garantisce visibilità ed ergonomia con l'uso dei driver brevettati **EASY INSERT**:

- è facilmente rimovibile dai pozzetti implantari anche in presenza di elevati torque di inserimento;
- il disegno dodecagonale previene le deformazioni agli spigoli delle connessioni garantendo il mantenimento della precisione e stabilità protesica;
- disponibile nel kit in diverse configurazioni, sia per uso con micromotore che con il cricchetto;
- gli strumenti presentano un esagono sul gambo, allineato con l'esagono della connessione, per facilitare l'orientamento rotazionale della fixture.

Kit Prama Power

Kit chirurgico completo degli strumenti necessari per l'inserimento degli impianti Prama Power (cod. ZPRAMA-INT).
Tutti gli strumenti possono essere acquistati singolarmente come ricambi.

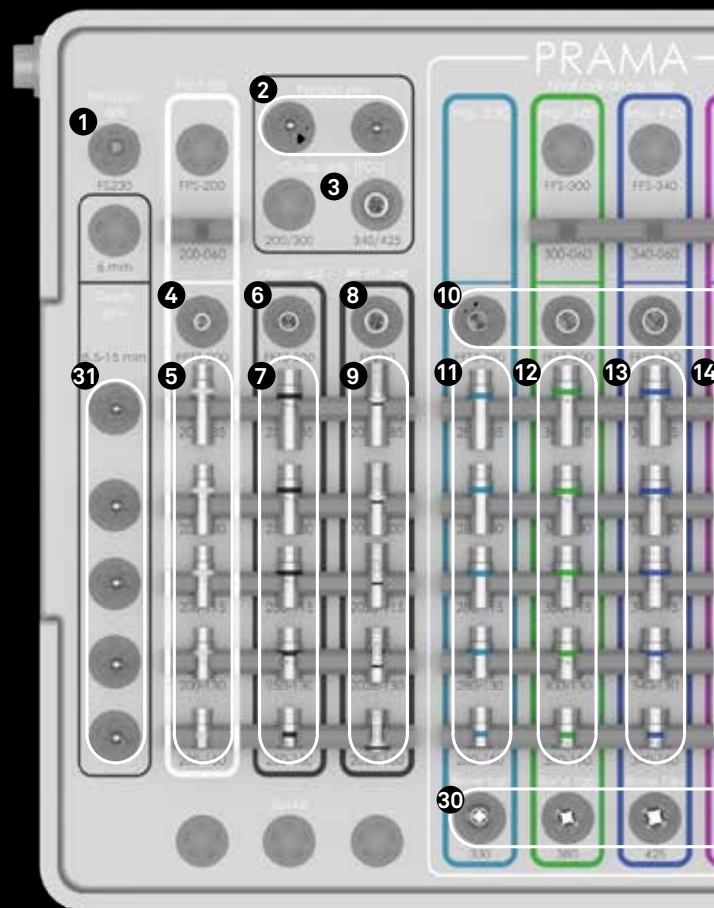
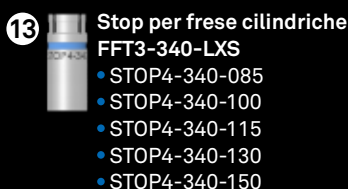
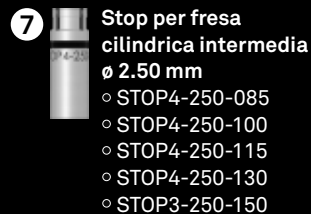

L-TRAYL-INT cassetta portastrumenti in Radel.

*Si veda pagina 37 per le avvertenze relative alle misure degli strumenti

Per le procedure chirurgiche e le relative avvertenze si raccomanda di prendere visione del Manuale chirurgico MC-IMP-PRAMA (scaricabile dal sito www.sweden-martina.com o inquadrando il QR CODE a fianco)



- 21** Stop per frese coniche
- SH-STOP4-FK380
 - SH-STOP4-FK425
 - SH-STOP4-FK500

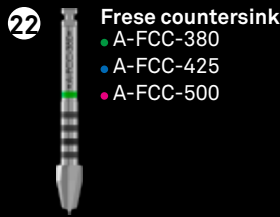

- 23** Driver per inserimento impianti Easy Insert
- EASYC4-EX230-CA

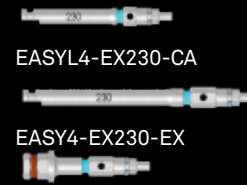

- 24** Avvitatori chirurgici digitali
- HSMXS-20-DG HSM-20-DG HSML-20-DG

- Avvitatori protesici
- HSM-20-CA HSM-20-EX HSML-20-EX

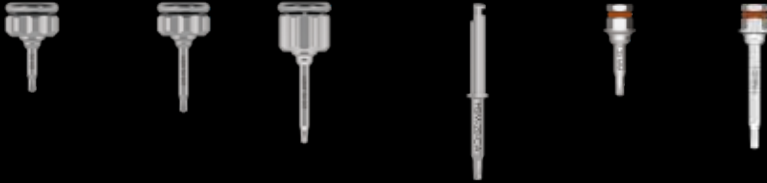

- 25** Cricchetto dinamometrico
- CRI5-KIT



- 26** Prolunghe e adattatore
- PROF-CAL3
Prolunga per frese chirurgiche



- BPM-15
Prolunga per strumenti con raccordo esagonale



- B-AVV-CA3
Adattatore con attacco per contrangolo per strumenti con raccordo esagonale



- 27** Adattatore per strumenti con attacco esagonale
- AVV3-MAN-DG

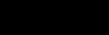

- 28** Adattatore per strumenti con attacco esagonale
- AVV-CA-DG-EX



- 29** Maschiatori conici
- SH-MS-380-CA
 - SH-MS-425-CA
 - SH-MS-500-CA



- 30** Maschiatori cilindrici
- SM-MS-330
 - A-MS-380
 - A-MS-425
 - A-MS-500



- 31** Perni per il posizionamento del collo
- L-PP-085
 - L-PP-100
 - L-PP-115
 - L-PP-130
 - L-PP-150



Lucidi radiografici inclusi nel kit, riordinabili separatamente con i codici L-L100 (dimensioni reali), L-L120 (dimensioni maggiorate del 20%), L-L130 (dimensioni maggiorate del 30%).

Kit chirurgico per la chirurgia guidata con impianti Prama Power

Kit chirurgico completo degli strumenti necessari per l'inserimento in chirurgia guidata degli impianti Prama Power (cod. ZGS-PRO-A-INT). Nel tray sono presenti alcuni alloggiamenti per strumenti riferiti a sistematiche diverse. Tali strumenti non sono pertanto inclusi nella dotazione standard del kit.



Frese opzionali per la preparazione di impianti h 18.00 mm.

18 Frese per la preparazione di impianti h 18.00 mm \varnothing 4.25
GS-F200-180-550
GS-F340-180-550

17 Frese per la preparazione di impianti h 18.00 mm \varnothing 3.80 mm
GS-F200-180-415
GS-F300-180-415

16 Pin e fresa per pin
GS-PIN (4 pcs) GS-FPN-148

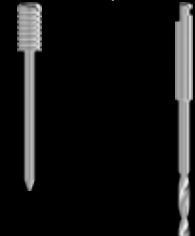

15 Adattatore per strumenti con attacco esagonale
AVV3-MAN-DG



14 Cricchetto dinamometrico
CRI5-KIT



13 Driver per montatori
EASY4-EX250-EX
EASYC4-EX250-CA



12 Frese da collo
GS-FCS-A380 per impianto \varnothing 3.80 mm
GS-FCS-A425 per impianto \varnothing 4.25 mm
GS-FCS-A500 per impianto \varnothing 5.00 mm

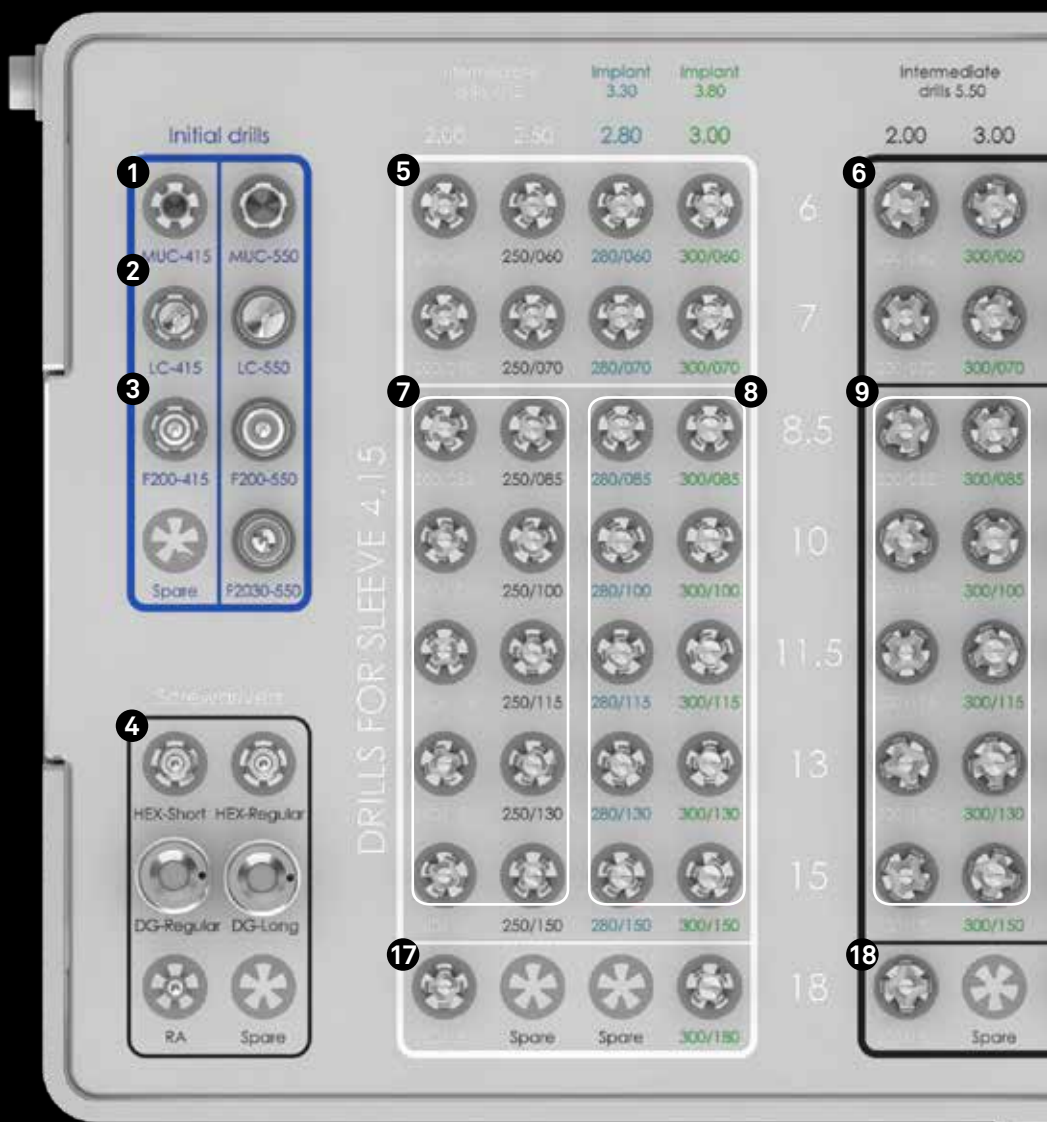

Kit chirurgico per la chirurgia guidata con impianti Prama RF Power e Prama RF SL Power

Kit chirurgico completo degli strumenti necessari per l'inserimento in chirurgia guidata degli impianti Prama RF Power e Prama RF SL Power (cod. ZGS-PRO-S-INT). Nel tray sono presenti alcuni alloggiamenti per strumenti riferiti a sistematiche diverse. Tali strumenti non sono pertanto inclusi nella dotazione standard di tali kit.



Mucotomi
GS-MUC-415
GS-MUC-550

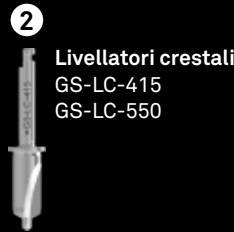

Livellatori crestali
GS-LC-415
GS-LC-550

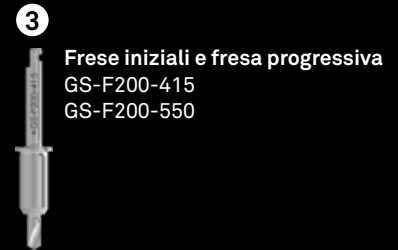

Frese iniziali e fresa progressiva
GS-F200-415
GS-F200-550

Frese opzionali per la preparazione di impianti h 6.00 mm, boccola 415:



GS-F200-060-415
GS-FK410U-060-415
GS-FK410-060-415

Frese opzionali per la preparazione di impianti h 6.00 mm, boccola 550:

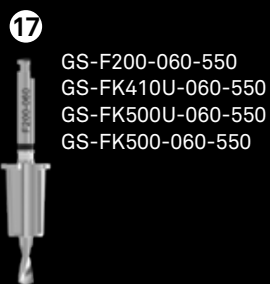

GS-F200-060-550
GS-FK410U-060-550
GS-FK500U-060-550
GS-FK500-060-550

Sono ordinabili anche cumulativamente come set integrativo con il codice GS-PROS-INTEGRA-060.



Adattatore per strumenti con attacco esagonale
AVV3-MAN-DG



Cricchetto dinamometrico
CRI5-KIT



Pin e fresa per pin
GS-FPN-148 GS-PIN (4 pcs)

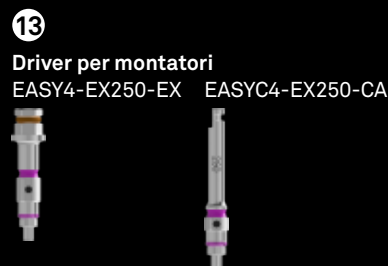



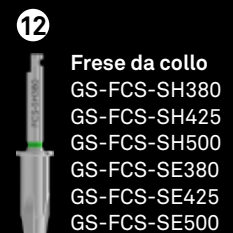



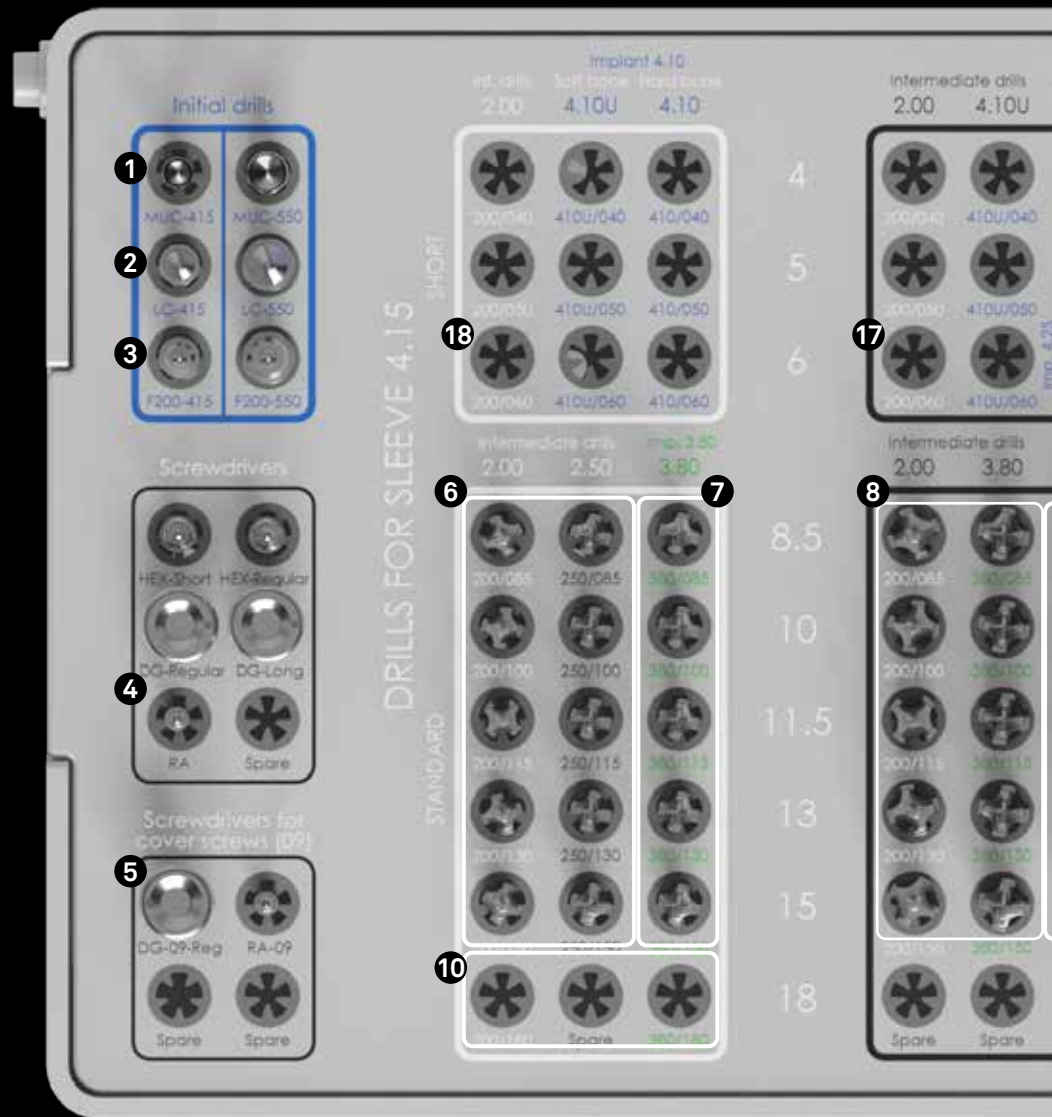



















Driver per montatori
EASY4-EX250-EX EASYC4-EX250-CA



Frese da collo
GS-FCS-SH380
GS-FCS-SH425
GS-FCS-SH500
GS-FCS-SE380
GS-FCS-SE425
GS-FCS-SE500



Complementi per chirurgia guidata

		3.30 ●		3.80 ●		4.25 ● - 5.00 ●	
		 4.00 GS-B415-EX-6*	 4.00 GS-B415-EX-6*	 4.00 GS-B550-EX-6*			
montatore	SHORT NECK	-	 7.20 GS-MOU2-L415-072	 7.20 GS-MOU2-L500-072			
	REGULAR NECK	 9.00 GS-MOU-A330	 6.20 GS-MOU-L415	 6.20 GS-MOU-L415	 6.20  9.00 GS-MOU-L550 GS-MOU-A380SP**		
	LONG NECK	-	 5.20 GS-MOU2-L415-052	 5.20 GS-MOU2-L500-052			
vite di serraggio fornita in dotazione		 GS-VTMOU-180**	 GS-VTMOU-180**	 GS-VTMOU-180***	 GS-VTMOU-180***		
easy mounter		 9.00 GS-EASY-AS-415-EX	 9.00 GS-EASY-L-415-EX	 9.00 GS-EASY-L-550-EX			
		 9.00 GS-EASY-AS-415-CA	 9.00 GS-EASY-L-415-CA	 9.00 GS-EASY-L-550-CA			
easy mounter con tacche di profondità		-	 GS-EASYPE-L-415-EX	 GS-EASYPE-L-550-EX			
		-	 GS-EASYPE-L-415-CA	 GS-EASYPE-L-550-CA			

*Le boccole guida indicizzate sono disponibili in confezioni da 6 pezzi, non in vendita singola. Sono disponibili in confezione da 6 pezzi anche le boccole guida non indicizzate ordinabili con i codici GS-B415-6 e GS-B550-6.

**Si raccomanda, con questo montatore, di adeguare la preparazione del sito implantare in modo da non superare il valore di torque di 50 Ncm.

30 ***La vite di serraggio è fornita in dotazione con il montatore ma è ordinabile anche singolarmente come ricambio.

Maschiatori senza stop

∅ implantare

3.30 ●

3.80 ●

4.25 ●

5.00 ●

Prama Power



GS-MSPE-A330



GS-MSPE-A380



GS-MSPE-A425



GS-MSPE-A500

Prama RF Power,
Prama RF SL Power



GS-MSPE-S380



GS-MSPE-S425



GS-MSPE-S500

Frese Countersink senza stop

∅ implantare

3.30 ●

3.80 ●

4.25 ●

5.00 ●

Prama Power



GS-FCSPE-380



GS-FCSPE-425



GS-FCSPE-500

Boccole per pin

confezione da 6 pezzi



GS-B150-PIN-6

Approfondisci le linee guida per
l'inserimento di Prama Power con
chirurgia guidata



Set integrativi opzionali

Set L-INTEGRA-060

Il set di frese L-INTEGRA-060 comprende i componenti necessari per l'inserimento degli impianti Prama Power e Prama RF Power h 6.00 mm, i cui alloggiamenti sono previsti all'interno del kit Prama Power.

Frese iniziali Prama Power h 6.00 mm*

fresa pilota

fresa intermedia Shorty



FPS-200

FGS-200/300



STOPS4-200-060

-

* Strumenti inclusi nel kit ZSHORTY-INT

Frese finali Prama Power h 6.00 mm*

ø 3.80 ●

ø 4.25 ●

ø 5.00 ●



FFS-300

FFS-340

FFS-425



STOPS4-300-060



STOPS4-340-060



STOPS4-425-060

* Strumenti inclusi nel kit ZSHORTY-INT

Perno di parallelismo

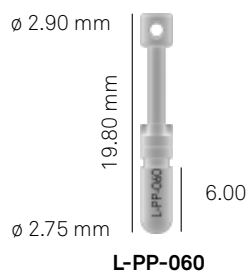

Frese finali Prama RF Power h 6.00 mm

ø 3.80 ●

ø 4.25 ●

ø 5.00 ●



-

SE-FK410

SE-FK500



SE-STOP-FK410-060



SE-STOP-FK500-060

Repliche Prama RF Power h 6.00 mm



SE-410-060-RP

SE-500-060-RP

Set L-INTEGRA

Il set di frese L-INTEGRA comprende i componenti necessari per l'inserimento dei Prama Slim Power \varnothing 3.30 mm, le frese countersink e i perni per il posizionamento del collo. Questi componenti sono inclusi all'interno della versione del kit chirurgico Prama Power inserita a catalogo, ma non nella versione precedente del kit, per cui rimangono a disposizione per coloro che hanno la versione precedente.

Perni per il posizionamento del collo



h	
8.5	L-PP-085
10.00	L-PP-100
11.50	L-PP-115
13.00	L-PP-130
15.00	L-PP-150

Strumentazione per Prama Slim Power

fresa finale

stop



FFT3-280-LXS



h	
8.50	STOP4-280-085
10.00	STOP4-280-100
11.50	STOP4-280-115
13.00	STOP4-280-130
15.00	STOP4-280-150

Strumenti chirurgici opzionali (non inclusi nel kit chirurgico Prama Power)

Fresa lanceolata lunga



FSL-230

Frese intermedie



FG-200/280XS

fresa intermedia 200/280



FG-330/425XS

fresa intermedia 330/425

Frese per settori distali

ø 2.00



FPT5-200-LXS

ø 3.30



FFT5-330-LXS

ø 2.80



FFT5-280-LXS

ø 3.40



FFT5-340-LXS

ø 2.90



FFT5-290-LXS

ø 3.60



FFT5-360-LXS

ø 3.00



FFT5-300-LXS

ø 4.25



FFT5-425-LXS

ø 3.20



FFT5-320-LXS

ø 4.45



FFT5-445-LXS

Avvitatori protesici non contenuti nei kit



HSMXL-20-EX

con raccordo esagonale, extra lungo



HSMXS-20-CA

con attacco per contrangolo, extra corto



L-HSM-EX

Full Head, con raccordo esagonale, corto



L-HSML-EX

Full Head, con raccordo esagonale, lungo



L-HSMXL-EX

Full Head, con raccordo esagonale, extra lungo



L-HSM-CA

Full Head, con attacco per contrangolo



AVV-CAP-TIT-1

strumento per la manutenzione della cappetta in titanio per attacchi sferici



BASCC-EX

per attacchi sferici, con raccordo esagonale



AVV2-ABUT

per abutment P.A.D. dritti



8926-SW

per abutment Locator, corto



8927-SW

per abutment Locator, lungo



DSPDCLH-24

per foro angolato, lunghezza 24 mm



DSPDCLH-32

per foro angolato, lunghezza 32 mm

Perni di parallelismo

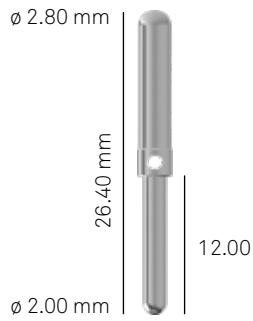

PP-2/28

perno di parallelismo con un lato di \varnothing 2.00 mm e l'altro di \varnothing 2.80 mm

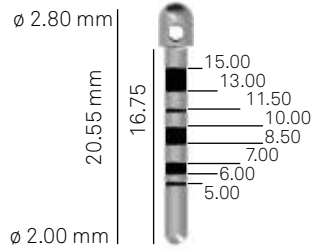

PPTS-2-28

perno di parallelismo con tacche di profondità, versione small

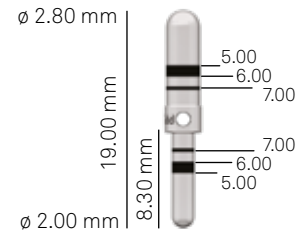

PPS-2/3

perno di parallelismo per frese corte con tacche a 5.00, 6.00 e 7.00 mm

Maschiatori

\varnothing 3.30 ●

\varnothing 3.80 ●

\varnothing 4.25 ●

\varnothing 5.00 ●

Maschiatori con raccordo esagonale



SM-MSC-330

A-MSC-380

A-MSC-425

A-MSC-500



-

SH-MS-380

SH-MS-425

SH-MS-500

Maschiatori con attacco per contrangolo



SM-MS-330-CA

A-MS-380-CA

A-MS-425-CA

A-MS-500-CA

Brugole per la rimozione degli impianti



BC-EX230

corta



BL-EX230

lunga

Estrattori per la rimozione atraumatica di impianti



EXTR-IMP-S

small



EXTR-IMP-M

medium



EXTR-IMP-L

large

Profilatori d'osso per abutment P.A.D.

piattaforma unica



A-PAD-PS330-L

h tras mucosa 3.00, largo

A-PAD-PS330-S

h tras mucosa 5.00, stretto



A-PAD-GUI-PS-230

guida per profilatore

Osteotomi



E-OS-020-PP

osteotomo \varnothing 0.20
punta piatta



E-OS-090-PP

osteotomo \varnothing 0.90
punta piatta



E-OS-160-PC

osteotomo \varnothing 1.60
punta concava



E-OS-200-PC

osteotomo \varnothing 2.00
punta concava



E-OS-240-PC

osteotomo \varnothing 2.40
punta concava

Osteotomi punta piatta



h	\varnothing 3.80 ●	\varnothing 4.25 ●	\varnothing 5.00 ●
8.50-10.00	SH-OS-380-100-PP	SH-OS-425-100-PP	SH-OS-500-100-PP
11.50	SH-OS-380-115-PP	SH-OS-425-115-PP	SH-OS-500-115-PP
13.00	SH-OS-380-130-PP	SH-OS-425-130-PP	SH-OS-500-130-PP
15.00	SH-OS-380-150-PP	SH-OS-425-150-PP	SH-OS-500-150-PP

Osteotomi punta rotonda



h	\varnothing 3.80 ●	\varnothing 4.25 ●	\varnothing 5.00 ●
8.50-10.00	SH-OS-380-100-PR	SH-OS-425-100-PR	SH-OS-500-100-PR
11.50	SH-OS-380-115-PR	SH-OS-425-115-PR	SH-OS-500-115-PR
13.00	SH-OS-380-130-PR	SH-OS-425-130-PR	SH-OS-500-130-PR
15.00	SH-OS-380-150-PR	SH-OS-425-150-PR	SH-OS-500-150-PR

Chiave dinamometrica opzionale con leva di controllo



TWL



TWL-AVV-EX avvitatore

Mounter di servizio per procedure a impatto



MOU-EX230 mounter



CM2 chiave ferma mounter

Profondimetro



PROF3

O-ring di ricambio



ORING180-088

Misuratore di profondità del tunnel mucoso



MP-LMRC-180

h 10 mm

Tacche di profondità

La marcatura laser presente sui taglienti e l'uso degli stop consentono una preparazione in totale sicurezza e il controllo della profondità d'inserimento dello strumento.

Le frese realizzano sempre un foro più lungo dell'impianto che si desidera inserire.

Il sovradimensionamento (LS) è pari all'altezza della punta della fresa che si sta utilizzando.

LL: Lunghezza totale della parte lavorante, inclusa la punta.

LS: Lunghezza della sovrappreparazione. Questa misura deve essere calcolata in aggiunta alla lunghezza del foro della preparazione.

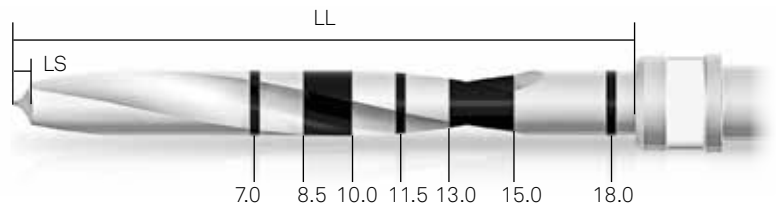

La profondità di lavoro è identificata anche su maschiatori e osteotomi tramite tacche laserate, come segue:

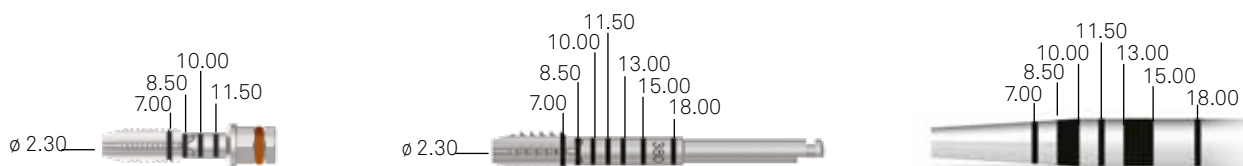

La profondità di lavoro è identificata anche su maschiatori senza stop e frese Countersink tramite tacche laserate, come segue:



Soluzioni protesiche d'eccellenza

Soluzioni senza spalla

Soluzioni convergenti senza spalla o base di appoggio, con profilo stretto o convergente, nei quali la corona può essere posizionata a diverse altezze (L-MD o L-MDT). Queste soluzioni favoriscono l'ispessimento dei tessuti molli perché lasciano più spazio al connettivo.



Soluzioni PRAMA IN

Quando la riabilitazione singola riguarda un ultimo elemento molare, si consiglia di utilizzare una soluzione protesica "Prama IN" che chiude intorno al collo implantare, consentendo una maggiore robustezza alla riabilitazione, anche alla luce degli importanti carichi masticatori tipici di quella zona. Le soluzioni protesiche "Prama IN" possono risultare una valida opzione anche nei casi in cui, per fattori legati alla risposta immunitaria del paziente, il rimodellamento osseo e tissutale raggiunto non fosse quello desiderato.



T-CONNECT

T-Connect standard o personalizzabili per foro vite dritto o angolato.

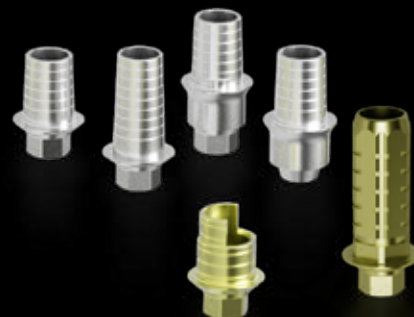

Linea CONICO

Sistema conometrico CONICO:

- Protesi fissa senza viti e senza cemento, facilmente rimovibile in pochi secondi da parte del medico per ispezione e igiene.
- Utilizzabile sia per corone singole che per riabilitazioni multiple.
- Sigillo biologico e mantenimento di tessuti sani stabili nel tempo.

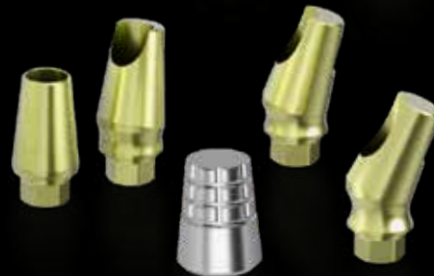

Abutment per protesi multipla PAD^e

- PAD^e: abutment semplici da inserire.
- Massima libertà ed ergonomia delle sovrastrutture.
- Anodizzazione rosa per un maggior mimetismo.
- L'ingombro limitato li rende ideali per riabilitazioni di arcate parzialmente o totalmente edentule in spazi orizzontali e verticali ridotti.



Ricorso al foro vite angolato

Nel caso di impianti in zona estetica anteriore con angolazione fra asse implantare e asse del moncone è spesso preferibile posizionare gli impianti Prama Power più in profondità e utilizzare basi o pilastri per incollaggio con foro vite angolato, in modo che la vite presenti una uscita palatale, coerente con le necessità estetiche.

Sono disponibili soluzioni per incollaggio con base di appoggio per la corona e soluzioni senza base di appoggio che lasciano la libertà al clinico di determinare dove chiudere la corona.

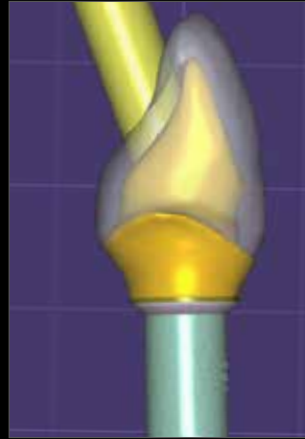

Courtesy of dr. Paolo Nardinocchi



L-MDT per foro vite angolato

Fase di impronta e modello

Transfer Pick-up

emergenza dritta

ø 3.30 ●

ø 3.80 ●

ø 4.25 ●

ø 5.00 ●

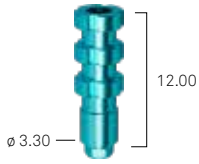

A-TRA-330

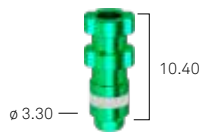

L-TRA-380

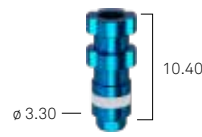

L-TRA-425



L-TRA-500

Vite VTRA2-180-15 inclusa.

Transfer Pull-up

emergenza dritta

piattaforma unica

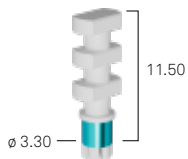

A-TRAP-330

Analoghi

ø 3.30 ●

ø 3.80 ●

ø 4.25 ●

ø 5.00 ●

Short Neck



A-ANA-330

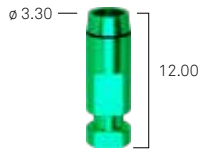

LS-ANA-380



LS-ANA-425

-

Regular Neck



A-ANA-330

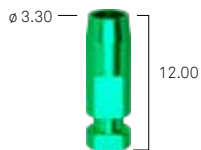

L-ANA-380



L-ANA-425



L-ANA-500

Long Neck

-



LL-ANA-380









LL-ANA-425

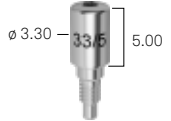
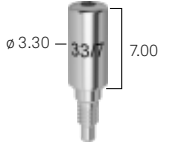

LL-ANA-500

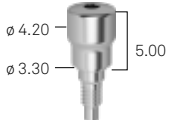
Transmucose di guarigione

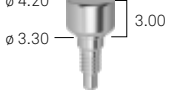
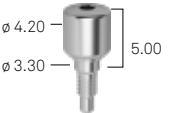
Transmucose di guarigione						
h transmucosa	2.00 mm	3.00 mm	4.00 mm	5.00 mm	5.00 mm	7.00 mm
con emergenza dritta piattaforma unica			-			
	A-TMG-330-2	A-TMG-330-3		A-TMG-330-5		A-TMG-330-7
con emergenza dritta con allargamento coronale piattaforma unica			-			-
	A-TMTCR-330-2	A-TMTCR-330-3		A-TMTCR-330-5		
con profilo ampio piattaforma unica						
	A-TMGB-330-2	A-TMGB-330-3	A-TMGB-330-4			

Transmucosa di guarigione piattaforma unica

in titanio Gr. 5

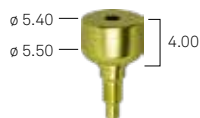

A-TMG-MEFL-330

Tecnica REGISTRA

Viti transfer anatomiche per tecnica REGISTRA

h	5.00 mm	7.00 mm	9.00 mm
vite transfer anatomica per Tecnica REGISTRA piattaforma unica			
	A-TO-330-5	A-TO-330-7	AS-TO-330-9

Cappetta transfer

cappetta universale per viti transfer REGISTRA



CAP-TO

Per maggiori dettagli consultare il catalogo C-IMP-REGISTRA

Guarda il videocorso gratuito sulla Tecnica REGISTRA



Transmucose di guarigione Prama IN

(con chiusura che ingloba il collo implantare)

in titanio							
h trans mucosa	h chiusura sul collo	Ø 3.80 ●	Ø 4.25 ●	Ø 5.00 ●			
2.50	0.50*				L-TMG-380-25-05	L-TMG-425-25-05	L-TMG-500-25-05
3.50	0.50*				L-TMG-380-35-05	L-TMG-425-35-05	L-TMG-500-35-05
2.50	1.50**				L-TMG-380-25-15	L-TMG-425-25-15	L-TMG-500-25-15
3.50	1.50**				L-TMG-380-35-15	L-TMG-425-35-15	L-TMG-500-35-15
in resina REEF							
h trans mucosa	h chiusura sul collo	Ø 3.80 ●	Ø 4.25 ●	Ø 5.00 ●			
6.00	0.50*				L-TMGPF-380-05	L-TMGPF-425-05	L-TMGPF-500-05
6.00	1.50**				L-TMGPF-380-15	L-TMGPF-425-15	L-TMGPF-500-15

Transmucose di guarigione in resina REEF: vite VM2-180 inclusa.
 *Solo per Regular e Long Neck. | **Solo per Regular Neck.

Pilastri provvisori

in resina REEF

piattaforma unica



A-PPF-330-EX

in resina REEF, riposizionabile

A-PPF-330

in resina REEF, non riposizionabile

Vite VM2-180 inclusa.

Simple in PEEK e titanio Gr. 5

piattaforma unica

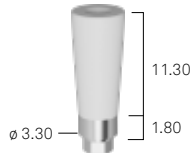

A-MPSC-330

Simple in PEEK, base in titanio Gr. 5, riposizionabile

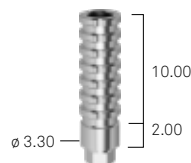

A-MPSCI-330-EX

Simple in titanio Gr. 5, riposizionabile

A-MPSCI-330

Simple in titanio Gr. 5, non riposizionabile

Vite VM2-180 inclusa.

in titanio con cannula calcinabile

piattaforma unica



A-CTI-330

in titanio con cannula calcinabile, non riposizionabili

A-CCI-S

cannula calcinabile piccola per tecnica per incollaggio (vite non inclusa)

Vite VM2-180 inclusa.

cannule lisce per incollaggio

piattaforma unica



L-CT-340-ROT

cannule in Ti Gr.5, h 14.00 mm, emergenza dritta

L-CCRCO-340-ROT

cannule in cromo cobalto, h 14.00 mm, emergenza dritta



L-CTR-340-ROT

cannule in Ti Gr.5, h 14.00 mm, emergenza anatomica

L-CCRCOR-340-ROT

cannule in cromo cobalto, h 14.00 mm, emergenza anatomica

Vite L-VMS-180 inclusa.

Pilastri preformati

Dritti

piattaforma unica	h pilastro			
	6.00	6.00	L-MD-340-6	riposizionabili
	8.00	8.00	L-MD-340-8	riposizionabili
	6.00	6.00	L-MD-340-6-ROT	riposizionabili
	8.00	8.00	L-MD-340-8-ROT	non riposizionabili

Vite L-VMS-180 inclusa.

Dritti, a finire

piattaforma unica	h pilastro			
	15.00	15.00	A-MD-330-15	riposizionabili





Vite L-VMS-180 inclusa.

Dritti, a finire

piattaforma unica	h pilastro			
	15.00	15.00	A-MD-330-15-ROT	non riposizionabili

Vite L-VMS-180 inclusa.

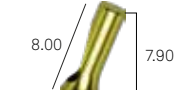
Angolati

piattaforma unica	h trans mucosa			
	0.00	0.00	L-MA15-340	
	1.00	1.00	L-MA15-340-1	angolati a 15°, riposizionabili
	2.00	2.00	L-MA15-340-2	
	1.00	1.00	L-MA25-340-1	angolati a 25°, riposizionabili
	2.00	2.00	L-MA25-340-2	

Vite L-VMS-180 inclusa, per L-MA15-340 vite L-VM-180 inclusa.

Pilastrì fresabili

Pilastrì fresabili

piattaforma unica

emergenza dritta



A-MF-330

emergenza ampia

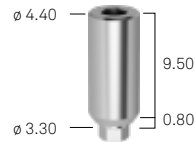

A-MFS-330

Vite VM2-180 inclusa.

Pilastrì calcinabili

Con base in metallo

piattaforma unica

base in cromo cobalto,
riposizionabili

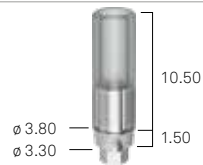

A-UCRCO-330-EX

base in cromo cobalto,
non riposizionabili

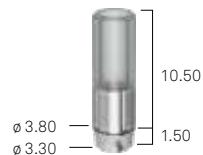

A-UCRCO-330

base in titanio,
non riposizionabili
solo per lavorazioni in titanio

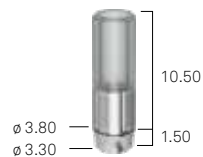

A-UCTR-330-EX

cannula calcinabile di
ricambio,
vite non inclusa

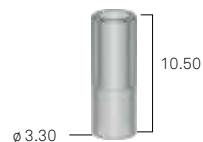

A-CCUCR-330

Vite VM2-180 inclusa.

Interamente calcinabili

piattaforma unica

riposizionabili,
emergenza dritta



A-CC-330-EX

non riposizionabili,
emergenza dritta

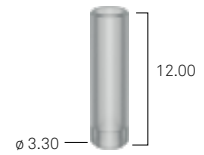

A-CC-330

Vite VM2-180 inclusa.

Soluzioni con foro vite angolato

Queste soluzioni presentano una peculiare morfologia, con una finestra laterale o con un elemento orientabile, che permette di dislocare il foro per la vite passante in posizione palatale o linguale, evitando così antiestetici fori vestibolari.

Abutment per foro angolato

piattaforma unica

base in cromo cobalto,
riposizionabili



PD3PKH330/CC

base in cromo cobalto, non
riposizionabili

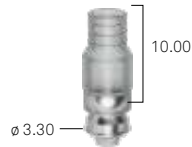

PD3PKR330/CC

interamente calcinabili,
riposizionabili

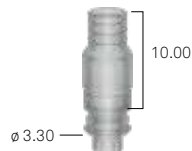

PD3PKH330/P

interamente calcinabili, non
riposizionabili



PD3PKR330/P



Interfase per foro vite angolato

piattaforma unica

riposizionabili



IND3PKH330/TIA

non riposizionabili



IND3PKR330/TIA

Vite A-VMA-180 non inclusa.

Interfase senza spalla di appoggio e con foro vite palatale

riposizionabili

piattaforma unica

h cono di cementazione

6.00 mm

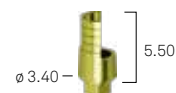

L-MDT-340-6

10.00 mm

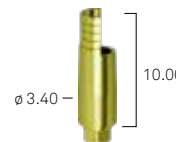

L-MDT-340-10

non riposizionabili

piattaforma unica

6.00 mm



L-MDT-340-6-ROT

10.00 mm

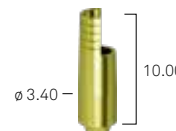





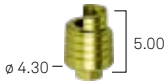

L-MDT-340-10-ROT

ATTENZIONE: La vite per foro angolato va sempre ordinata separatamente perchè non inclusa nella confezione delle Interfasi. Qualora non si disponesse dell'apposito cacciavite DSPDCLH-24 o DSPDCLH-32 si prega di ordinarlo a parte.

Per questi componenti utilizzare la vite standard VM2-180 o la vite per foro angolato A-VMA-180. Le viti non sono incluse.

T-Connect Prama IN con chiusura sul collo a 0.50 mm

h cono di cementazione		ø 3.80 ●	ø 4.25 ●	ø 5.00 ●
riposizionabili	5.00 mm	 L-TCIN-380-05	 L-TCIN-425-05	 L-TCIN-500-05
non riposizionabili	5.00 mm	 L-TCIN-380-05-ROT	 L-TCIN-425-05-ROT	 L-TCIN-500-05-ROT



Solo per Regular e Long Neck | Per questi componenti utilizzare la vite standard VM2-180 o la vite per foro angolato A-VMA-180. Le viti non sono incluse.

T-Connect Prama IN con chiusura sul collo a 1.00 mm (Regular Neck)

h cono di cementazione		ø 3.80 ●	ø 4.25 ●	ø 5.00 ●
riposizionabili	5.00 mm	 L-TCIN-380-10	 L-TCIN-425-10	 L-TCIN-500-10





Solo per Regular Neck | Per questi componenti utilizzare la vite standard VM2-180 o la vite per foro angolato A-VMA-180. Le viti non sono incluse.

T-Connect Prama IN con chiusura sul collo a 1.00 mm (Long Neck)

h cono di cementazione		ø 3.80	ø 4.25	ø 5.00
riposizionabili	5.00 mm	 LL-TCIN-380-10	 LL-TCIN-425-10	 LL-TCIN-500-10

Solo per Long Neck | Per questi componenti utilizzare la vite standard VM2-180 o la vite per foro angolato A-VMA-180. Le viti non sono incluse.

T-Connect T-CUT (Prama IN) tagliabile con chiusura sul collo a 0.50 mm

h cono di cementazione		ø 3.80 ●	ø 4.25 ●	ø 5.00 ●
	8.00 mm	 L-TCIN-380-05-8	 L-TCIN-425-05-8	 L-TCIN-500-05-8
	8.00 mm	 L-TCIN-380-05-8-ROT	 L-TCIN-425-05-8-ROT	 L-TCIN-500-05-8-ROT



Solo per Regular e Long Neck | Per questi componenti utilizzare la vite standard VM2-180 o la vite per foro angolato A-VMA-180. Le viti non sono incluse.

T-Connect T-CUT (Prama IN) tagliabile con chiusura sul collo a 1.00 mm (Regular Neck)

h cono di cementazione		ø 3.80 ●	ø 4.25 ●	ø 5.00 ●
	8.00 mm	 L-TCIN-380-10-8	 L-TCIN-425-10-8	 L-TCIN-500-10-8

Solo per Regular Neck | Per questi componenti utilizzare la vite standard VM2-180 o la vite per foro angolato A-VMA-180. Le viti non sono incluse.

T-Connect T-CUT (Prama IN) tagliabile con chiusura sul collo a 1.00 mm (Long Neck)

h cono di cementazione		ø 3.80	ø 4.25	ø 5.00
	8.00 mm	 LL-TCIN-380-10-8	 LL-TCIN-425-10-8	 LL-TCIN-500-10-8

Solo per Long Neck | Per questi componenti utilizzare la vite standard VM2-180 o la vite per foro angolato A-VMA-180. Le viti non sono incluse.

ATTENZIONE: La vite per foro angolato va sempre ordinata separatamente perchè non inclusa nella confezione delle Interfasi. Qualora non si disponesse dell'apposito cacciavite DSPDCLH-24 o DSPDCLH-32 si prega di ordinarlo a parte.

Linea protesica PAD^e (Protesi Avvitata Disparallela Estetica)

Abutment PADe dritti ad avvitamento diretto Connessione Collex One

h transmucosa

piattaforma unica

1.50 mm



A-PADE-AD330-15

3.00 mm



A-PADE-AD330-30

5.00 mm

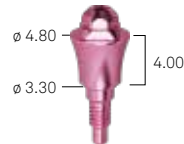

A-PADE-AD330-40

Carrier PADR-VTRAL-140-M incluso: per l'avvitamento intraorale utilizzare l'apposito avvitatore AVV2-ABUT.

Abutment PADe angolati connessione Collex One

piattaforma unica

angolati a 17°
h transmucosa 3.00 mm



A-PADE-AA330-173

angolati a 17°
h transmucosa 5.00 mm



A-PADE-AA330-175

angolati a 30°
h transmucosa 3.00 mm



A-PADE-AA330-303

angolati a 30°
h transmucosa 5.00 mm



A-PADE-AA330-305

angolati a 45°
h transmucosa 3.00 mm



A-PADE-AA330-453

angolati a 45°
h transmucosa 5.00 mm



A-PADE-AA330-455

Vite PADR-VM-180 inclusa.

Carrier PADR-VTRAL-140-M incluso: per l'avvitamento intraorale utilizzare l'apposito cacciavite della serie HSM.

Componenti per sovrastrutture su PADe

Cuffie di guarigione

cuffia di guarigione in titanio

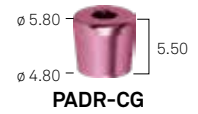

PADR-CG

cuffia di guarigione in PEEK



PADR-CGP

PADR-CG: vite PAD-VP-140 inclusa. | PADR-CGP: vite PAD-VCGP-140 inclusa.

Componenti per ribasatura e tecnica per incollaggio

cannula in PEEK, non indicizzata

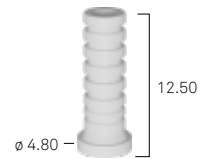

PADR-CP

cannula in titanio, non indicizzata



PADR-CT

cannula calcinabile in PMMA
(vite non inclusa)

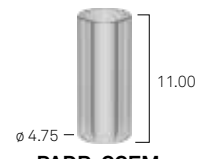

PADR-CCEM

cannula calcinabile in PMMA,
non indicizzata



PADR-CC

cannula in titanio senza spalla,
per ricostruzioni estetiche



PADR-BAS

Cannule in PEEK, Titanio Gr. 5 e PMMA: vite PAD-VP-140 inclusa.

Pilastro calcinabile con base in metallo

pilastro in PMMA con base in cromo
cobalto, non riposizionabile



PADR-UCRCO

Vite PAD-VP-140 inclusa.

Presca d'impronta

cappetta snap-on per impronta

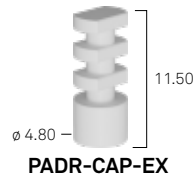

PADR-CAP-EX

transfer pick-up, non riposizionabile



PADR-TRA

analogo



PADR-ANA

Transfer Pick up: vite PAD-VTRAL-140 inclusa.

Componenti per protesi digitale

scanbody intraorale



PADR-INT-CAMTRA-L

Scanbody intraorale per avvitamento diretto**



Y-AVV-SB-DIG-NX

analogo digitale per abutment PADe



PADR-ANA-DIG

cannula per incollaggio rotante per abutment con cono h. 4



PADR-TC-M-4

cannula per incollaggio rotante per abutment con cono h 8 con tacche di riduzione



PADR-TC-M-8

cannula per incollaggio rotante per abutment per foro angolato



PADR-TCA-M*

cannula riposizionabile per incollaggio per abutment con cono h. 4



PADR-TC-S-4

cannula riposizionabile per incollaggio per abutment con cono h. 8 con tacche di riduzione



PADR-TC-S-8

cannula riposizionabile per incollaggio per abutment per foro angolato



PADR-TCA-S*

sleeve calcinabile rotante per PADR-TC-M-4 e PADR-TC-M-8



PADR-TC-CC-M-8

sleeve calcinabile indicizzata per PADR-TCA-M



PADR-TC-CC-S-8

Scanbody e cannule per incollaggio: vite PAD-VP-140 inclusa.

Analogo digitale: vite VADIG-180 inclusa.

*Cannula per incollaggio rotante per abutment per foro angolato: vite PAD-VPA-140 non inclusa.

**Avvitatore YV-CV-MAN-M.

Linea protesica PLAIN B-Space

Abutment

h transmucosa

piattaforma unica

2.00 mm



A-PLAIN-ABU330-2

3.00 mm



A-PLAIN-ABU330-3

4.00 mm



A-PLAIN-ABU330-4

Componenti per sovrastrutture

piattaforma unica

cuffie di guarigione



A-PLAIN-CG330

cannule calcinabili

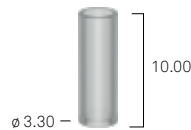

A-PLAIN-CC330

cannule in titanio Gr. 5



A-PLAIN-CT330

transfer Pick-up

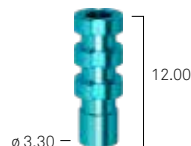

A-PLAIN-TRA-330

analoghi

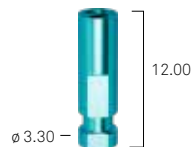

A-PLAIN-ANA-330

Cannule calcinabili e cannule in titanio: vite A-PLAIN-VP200 inclusa.
Transfer Pick-up: vite A-PLAIN-VTRA200 inclusa.

Componenti PLAIN B-Space per protesi digitale

piattaforma unica

scanbody per laboratorio e per uso intraorale in titanio per abutment PLAIN

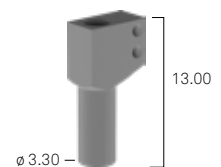

A-INT-CAMTRA-PLAIN-L

analogo digitale per abutment B-Space

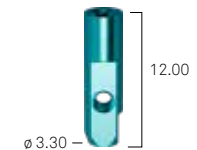

A-PLAIN-ANA-330-DIG

cannula per incollaggio PLAIN B-Space h 6.00 mm

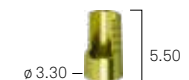

A-PLAIN-MDT-6

cannula per incollaggio PLAIN B-Space h 10.00 mm



A-PLAIN-MDT-10

Scanbody: vite A-PLAIN-VP200 inclusa.

Analogo digitale: vite VADIG-180 inclusa.

Cannule per incollaggio PLAIN B-Space: vite non inclusa.

Ordinabile separatamente vite per foro dritto A-PLAIN-VP200 o vite per foro angolato ABU-VMA-200.







Protesi conometrica Conico

Dritti



h	piattaforma unica
0.50	 <p>A-MD-TS-330-05</p>
1.00	 <p>A-MD-TS-330-10</p>
2.00	 <p>A-MD-TS-330-20</p>
3.00	 <p>A-MD-TS-330-30</p>

Vite VM2-180 inclusa.

Componenti Conico



cappetta per protesi fissa parziale o full-arch	 <p>CAP2-TS-DEF</p>
cappetta antirotativa per elemento singolo	 <p>CAP2-TS-IND</p>
cappetta per la rimozione	 <p>CAP2-TS-REM</p>
cappetta transfer in PEEK per impronta su abutment Conico	 <p>CAP2-TS-IMP</p>
analogo pilastro Conico	 <p>ANA2-MD-TS</p>
cappetta con pin da utilizzare per saldatura intraorale <i>(barre per saldatura disponibili su richiesta)</i>	 <p>CAP2-TS-PIN</p>

Angolati

	piattaforma unica
angolati a 7.5°	 <p>A-MA07-TS-330-2</p>
angolati a 15°	 <p>A-MA15-TS-330-2</p>
angolati a 22.5°	 <p>A-MA20-TS-330-2</p>



Vite VM2-180 inclusa.

Accessori Conico

parallelometro	 <p>PAR-PP</p>
inserto per parallelometro	 <p>PAR-INS-AS</p>
driver per parallelometro	 <p>CAP2-TS-PAR</p>

Si ricorda di acquistare sempre il parallelometro con l'inserto relativo alla connessione implantare sulla quale si deve utilizzare.















Componenti Conico per protesi digitale

	piattaforma unica
scanbody per laboratorio e per uso intraorale in titanio per sistemica Conico	 <p>C-INT-CAMTRA-L</p>
analogo digitale per abutment Conico	 <p>ANA2-MD-TS-DIG</p>

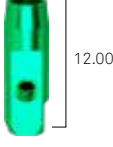
Analogo digitale: vite VADIG-180 inclusa.

Componenti per protesi digitale







Componenti per impronta e modello platform level

	ø 3.30 ●	ø 3.80 ●	ø 4.25 ●	ø 5.00 ●
scanbody*	 L-INT-CAMTRA-L	 L-INT-CAMTRA-L	 L-INT-CAMTRA-L	 L-INT-CAMTRA-L
analogo digitale short neck**	 A-ANA-330-DIG	 LS-ANA-380-DIG	 LS-ANA-425-DIG	-
analogo digitale regular neck**	 A-ANA-330-DIG	 L-ANA-380-DIG	 L-ANA-425-DIG	 L-ANA-500-DIG
analogo digitale long neck**	-	 LL-ANA-380-DIG	 LL-ANA-425-DIG	 LL-ANA-500-DIG

* Vite VM2-180 inclusa. | ** Vite VADIG-180 inclusa.

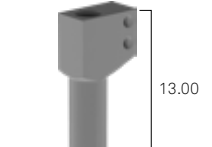

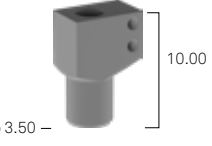



Componenti per impronta e modello abutment level

piattaforma unica







per abutment P.A.D.r	 PADR-INT-CAMTRA-L	 PADR-ANA-DIG
per abutment PLAIN B-Space	 A-INT-CAMTRA-PLAIN-L	 A-PLAIN-ANA-330-DIG
per sistemica Conico	 C-INT-CAMTRA-L	 ANA2-MD-TS-DIG

Viti e Avvitatori per analoghi digitali

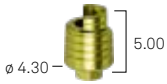
piattaforma unica

 VADIG-180 vite per analogo digitale M 1.8	 PIN-ANA-DIG pin per analogo digitale	 INS-ANA-140 carrier per inserimento analogo digitale M 1.4 P.A.D.r	 INS-ANA-180 carrier per inserimento analogo digitale M 1.8	 INS-ANA-180-L carrier per inserimento analogo digitale M 1.8, lungo	 INS-ANA-200 carrier per inserimento analogo digitale M 2.0 Conico
---	--	--	--	---	---

T-Connect Prama IN con chiusura sul collo a 0.50 mm

h cono di cementazione		ø 3.80 ●	ø 4.25 ●	ø 5.00 ●
riposizionabili	5.00 mm	 L-TCIN-380-05	 L-TCIN-425-05	 L-TCIN-500-05
non riposizionabili	5.00 mm	 L-TCIN-380-05-ROT	 L-TCIN-425-05-ROT	 L-TCIN-500-05-ROT



Solo per Regular e Long Neck | Per questi componenti utilizzare la vite standard VM2-180 o la vite per foro angolato A-VMA-180. Le viti non sono incluse.

T-Connect Prama IN con chiusura sul collo a 1.00 mm (Regular Neck)

h cono di cementazione		ø 3.80 ●	ø 4.25 ●	ø 5.00 ●
riposizionabili	5.00 mm	 L-TCIN-380-10	 L-TCIN-425-10	 L-TCIN-500-10







Solo per Regular Neck | Per questi componenti utilizzare la vite standard VM2-180 o la vite per foro angolato A-VMA-180. Le viti non sono incluse.

T-Connect Prama IN con chiusura sul collo a 1.00 mm (Long Neck)

h cono di cementazione		ø 3.80	ø 4.25	ø 5.00
riposizionabili	5.00 mm	 LL-TCIN-380-10	 LL-TCIN-425-10	 LL-TCIN-500-10

Solo per Long Neck | Per questi componenti utilizzare la vite standard VM2-180 o la vite per foro angolato A-VMA-180. Le viti non sono incluse.

T-Connect T-CUT (Prama IN) tagliabile con chiusura sul collo a 0.50 mm

h cono di cementazione		ø 3.80 ●	ø 4.25 ●	ø 5.00 ●
	8.00 mm	 L-TCIN-380-05-8	 L-TCIN-425-05-8	 L-TCIN-500-05-8
	8.00 mm	 L-TCIN-380-05-8-ROT	 L-TCIN-425-05-8-ROT	 L-TCIN-500-05-8-ROT



Solo per Regular e Long Neck | Per questi componenti utilizzare la vite standard VM2-180 o la vite per foro angolato A-VMA-180. Le viti non sono incluse.

T-Connect T-CUT (Prama IN) tagliabile con chiusura sul collo a 1.00 mm (Regular Neck)

h cono di cementazione		ø 3.80 ●	ø 4.25 ●	ø 5.00 ●
	8.00 mm	 L-TCIN-380-10-8	 L-TCIN-425-10-8	 L-TCIN-500-10-8

Solo per Regular Neck | Per questi componenti utilizzare la vite standard VM2-180 o la vite per foro angolato A-VMA-180. Le viti non sono incluse.

T-Connect T-CUT (Prama IN) tagliabile con chiusura sul collo a 1.00 mm (Long Neck)

h cono di cementazione		ø 3.80	ø 4.25	ø 5.00
	8.00 mm	 LL-TCIN-380-10-8	 LL-TCIN-425-10-8	 LL-TCIN-500-10-8

Solo per Long Neck | Per questi componenti utilizzare la vite standard VM2-180 o la vite per foro angolato A-VMA-180. Le viti non sono incluse.

ATTENZIONE: La vite per foro angolato va sempre ordinata separatamente perchè non inclusa nella confezione delle Interfasi. Qualora non si disponesse dell'apposito cacciavite DSPDCLH-24 o DSPDCLH-32 si prega di ordinarlo a parte.

Premilled

Platform level

piattaforma unica

riposizionabili



in titanio

A-CAMT-330-12-SW



in cromo cobalto

A-CAMC-330-12-SW

Vite VM2-180 inclusa.

Prama IN con chiusura sul collo a 0.50 mm*

Ø 3.80 ●

Ø 4.25 ●

Ø 5.00 ●

riposizionabili



in titanio

L-CAMT-38005-12-SW



L-CAMT-42505-12-SW



L-CAMT-50005-12-SW

Vite VM2-180 inclusa. | *Solo per Regular e Long Neck.

Platform level

piattaforma unica

riposizionabili

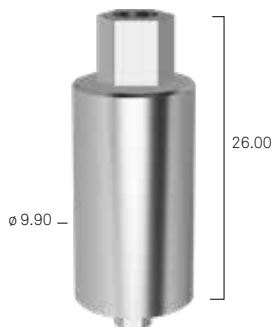

in titanio

A-CAMTABU330-CRE

Vite VM2-180 inclusa.

Soluzioni per overdenture

Attacchi sferici

piattaforma unica

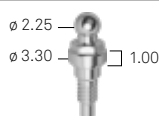

A-AS-330-1

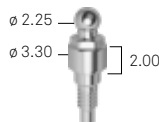

A-AS-330-2

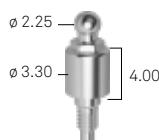

A-AS-330-4

Analogo per attacchi sferici

piattaforma unica



ANAS

Cappette per attacchi sferici

piattaforma unica

cappette in poliammide



040CRNSNDR8-SM*

contenitori in acciaio per cappetta, diametro esterno \varnothing 4.80 mm



041CAN-SM*

cappette in titanio Gr. 5, complete di cuffia in 2 parti, molla di ritenzione in titanio e anello di montaggio in plastica



CAP-TIT-1

anelli in plastica di ricambio



AN-CAP-TIT-1

molle di ritenzione di ricambio per cuffie in titanio, media durezza



MOL1-CAP-TIT-1

molle di ritenzione di ricambio per cuffie in titanio, morbida



MOL2-CAP-TIT-1

cappette in lega aurea, complete di 3 anelli di plastica e un distanziatore in stagno da laboratorio



CAP-1

* Confezione da 6 pezzi.

Overdenture su barre

barre calcinabili, l 5.00 cm, h 3.00 mm, spessore 2.20 mm, profilo ovoidale con spaziatore



BARC-CAV-TIT

cavalieri divisibili in titanio per barre ovoidali, h 3.00 mm, spessore 2.20 mm



CAV-TIT

barre calcinabili, l 5.00 cm, \varnothing 2.20 mm



BARC

cavalieri in lega aurea per barre tonde di \varnothing 2.20 mm











CAV-375





Abutment Locator

h transmucosa	piattaforma unica
1.00 mm	 <p>1670</p>
2.00 mm	 <p>1671</p>
3.00 mm	 <p>1672</p>
4.00 mm	-
5.00 mm	 <p>1674</p>
6.00 mm	-

Accessori per abutment Locator

	piattaforma unica
4 analoghi in alluminio	 <p>8530</p>
4 transfer in alluminio, 4 ritentori cod. 8515 inclusi	 <p>8505</p>
4 perni di parallelismo in polietilene	 <p>8517</p>
piastrine in acciaio AISI 316 L	 <p>9530</p>
Locator Core Tool completo	 <p>8393</p>
puntale in acciaio per inserimento dei ritentori	 <p>8397</p>
driver in acciaio per avvitamento/svitamento abutment	 <p>8390</p>
camicie di ritenzione per driver, per il trasporto degli abutment nel cavo orale	 <p>8394</p>





Cappette e ritentori per abutment Locator

	piattaforma unica
ritenzione bassa per presa d'impronta, in polietilene, nero confezione da 4 unità	 <p>8515</p>
ritenzione 5 lb = 2268 g, in nylon, disparallelismi fino a 10° per lato, confezione da 4 unità	 <p>8524</p>
ritenzione 3 lb = 1361 g, in nylon, disparallelismi fino a 10° per lato, confezione da 4 unità	 <p>8527</p>
ritenzione 1,5 lb = 680 g, in nylon, disparallelismi fino a 10° per lato, confezione da 4 unità	 <p>8529</p>
ritenzione 4 lb = 1814 g, in nylon, disparallelismi fino a 20° per lato, confezione da 4 unità	 <p>8547</p>
ritenzione 2 lb = 907 g, in nylon, disparallelismi fino a 20° per lato, confezione da 4 unità	 <p>8915</p>
ritenzione 1 lb = 450 g, in nylon, disparallelismi fino a 20° per lato, confezione da 4 unità	 <p>8548</p>
anellini distanziatori in gomma silconica di ricambio, confezione da 20 unità	 <p>8514</p>
kit con 2 cappette in titanio Gr. 5, 2 anellini distanziatori, 2 ritentori neri, 2 ritentori per ciascuna delle 3 diverse capacità di ritenzione	 <p>8519-2</p>
kit con 2 cappette in titanio Gr. 5, 2 anellini distanziatori, 2 ritentori neri, 2 ritentori per ciascuna delle 3 diverse capacità di ritenzione per grandi disparallelismi	 <p>8540-2</p>
kit con 2 cappette in acciaio, 2 anellini distanziatori, 2 ritentori neri, 2 ritentori per ciascuna delle 3 diverse capacità di ritenzione	 <p>8550-2</p>

Abutment Locator R-Tx*

h transmucosa

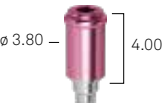





piattaforma unica

1.00 mm		1.00	31110-01
2.00 mm		2.00	31110-02
3.00 mm		3.00	31110-03
4.00 mm		4.00	31110-04
5.00 mm		5.00	31110-05
6.00 mm		6.00	31110-06

* Confezionamento All-in-One che include un abutment, un anello distanziatore, una cappetta e un inserto per ogni ritenzione (grigio, blu, rosa, bianco).









Cappette e ritentori per abutment Locator R-Tx

piattaforma unica

conf. da n. 4 cappette e 4 ritentori neri per la presa d'impronta		30013
conf. da n. 4 inserti grigi, senza ritenzione		30001
conf. da n. 4 inserti blu, a bassa ritenzione		30002
conf. da n. 4 inserti rosa, a media ritenzione		30003
conf. da n. 4 inserti bianchi, ad alta ritenzione		30004
conf. da n. 4 ritentori in plastica neri per la presa d'impronta		30012

Accessori per abutment Locator R-Tx

piattaforma unica

conf. da n. 4 analoghi in alluminio del Locator R-Tx \varnothing 3.35 mm		30014
conf. da n. 4 analoghi in alluminio del Locator R-Tx \varnothing 4.00 mm		30015
conf. da n. 4 analoghi in alluminio del Locator R-Tx \varnothing 5.00 mm		30016
conf. da n. 4 transfer per Locator R-Tx con bassa ritenzione, misura unica		30017
conf. da n.4 cappette spaziatrici per realizzazione o ribasatura protesi		30018
Locator core tool per Locator R-Tx		30021
avvitatore per contrangolo per Locator R-Tx, hex. 1.25 mm		08008
avvitatore digitale per Locator R-Tx, hex. 1.25 mm		08007

Viti protesiche cliniche e da laboratorio

Viti di serraggio standard

	VM2-180	
	VM2-180-10	confezione da 10 unità

Viti di serraggio ad appoggio conico

	L-VMS-180	
	L-VMS-180-10	confezione da 10 unità



Viti di serraggio con tecnologia Full Head

	L-VM-180	
	L-VM-180-10	confezione da 10 unità

Viti di serraggio per foro vite angolato

	A-VMA-180	
--	-----------	--



Viti per transfer Pick-up

	VTRA2-180-15	h 15.00
	VTRA2-180-20	h 20.00
	VTRA2-180-MAN	per avvitamento manuale

Viti di serraggio per transfer a strappo

	VTRA2-180-10	h 10.00
--	--------------	---------







Viti per abutment PLAIN

	A-PLAIN-VP200	per abutment PLAIN
	A-PLAIN-VP200-10	per abutment PLAIN, conf. da 10 unità
	A-PLAIN-VTRA200	per transfer Pick-up per abutment PLAIN
	ABU-VMA-200	vite per foro angolato





Viti protesiche M1.8 per Full Arch, autocentranti

	VM2-180-V-10	confezione da 10 unità
--	--------------	------------------------

Viti per abutment PADe

	PADR-VM-180	per abutment PADe
	PADR-VM-180-10	per abutment PADe, conf. da 10 unità
	PAD-VTRAL-140	per transfer Pick-up, lunga
	PAD-VTRA-140	per transfer Pick-up, standard
	PAD-VTRAL-140-MAN	per transfer Pick-up, per avvitamento manuale
	PAD-VP-140	per componenti protesiche su abutment PADe
	PAD-VP-140-10	per componenti protesiche su abutment PADe, conf. da 10 unità
	PAD-VPA-140	vite di serraggio per PADR-TCA-M da utilizzare con i cacciaviti dedicati DSPDCLH-24 e DSPDCLH-32
	PADR-VTRAL-140-M	carrier per PADe

Viti di serraggio per protesi CAD-CAM

	A-CAMTVABU180	per serraggio di pilastri individuali o sovrastrutture ECHO in ossido di zirconio
	PAD-VCAM140	per serraggio di sovrastrutture in ossido di zirconio su abutment PADe
	CAMPRON205-10	anellini di ammortizzazione della testa della vite di serraggio
	VADIG-180	vite di bloccaggio degli analoghi digitali

Torque raccomandato per il serraggio delle componenti protesiche

8-10 Ncm	viti chirurgiche di chiusura, transmucose di guarigione, viti per transfer
20-25 Ncm	tutte le viti protesiche
25-30 Ncm	tutte le componenti protesiche ad avvitamento diretto su impianto
8-10 Ncm	viti di serraggio transfer

Avvertenza importante

Le viti di serraggio sono sempre incluse nelle confezioni di ciascun componente protesico, salvo dove espressamente indicato. Si raccomanda di utilizzare viti di prova per le fasi di laboratorio e di conservare la nuova vite in dotazione per il fissaggio definitivo in bocca.

Bibliografia

- a. Canullo L., Tallarico M., Pradies G., Marinotti F., Loi I., Cocchetto R.,
Soft and hard tissue response to an implant with a convergent collar in the esthetic area: preliminary report at 18 months,
Int J Esthet Dent 2017; 12:2-19:
- b. Canullo L, Menini M, Covani U, Pesce P,
Clinical outcomes of using a prosthetic protocol to rehabilitate tissue-level implants with a convergent collar in the esthetic zone: a 3-year prospective study,
J Prosthet Dent. 2019 Jun 18. pii: S0022-3913(19)30077-0. doi: 10.1016/j.prosdent.2018.12.022
- c. Valente N.A., Wu M., Toti P., Derchi G., Barone A,
Concave/convergent versus parallel/divergent implant transmucosal profiles impact on hard and soft peri-implant tissues: a systematic review with meta-analysis,
Int J Prosthodont. Sep/Oct 2020;33(5):553-564. doi: 10.11607/ijp.6726
- d. Cabanes Gumbau G, Pascual-Moscardò A, Penarrocha-Oltra D, Garcia-Mira B, Aizcorbe-Vicente J, Penarrocha-Diago M,
Volumetric variation of peri-implant soft tissues in convergent collar implants and crowns using the biologically oriented preparation technique,
Med Oral Patol Oral Cir Bucal. 2019 Sep 1;24(5):e643-e651. doi: 10.4317/medoral.22946
- e. Agustín-Panadero R, Martínez-Martínez N, L. Fernandez-Estevan, J. Faus-Lopez, F. Sola-Ruiz,
Influence of transmucosal Area Morphology on Peri-implant bone loss in tissue-level implants,
The International Journal of Oral & Maxillofacial Implants, 2019; 34: 947-952. doi: 10.11607/jomi.7329
- f. Marchio V, Derchi G, Cinquini C, Miceli M, Gabriele M, Alfonsi F, Barone A,
Tissue level implants in healthy versus medically compromised patients: a cohort comparative study,
Minerva Stomatologica 2020 mese;69(0):000-000, Doi: 10.23736/S0026-4970.20.04359-9
- g. Prati C, Zamparini F, Canullo L, Pirani C, Botticelli D, Gandolfi MG,
Factors affecting soft and hard tissues around two-piece transmucosal implants: a 3 year prospective cohort study,
J Oral Maxillofac Implants 2020;35, doi: 10.11607/jomi.7778
- h. Agustín-Panadero, R.; Bermúdez-Mulet, I.; Fernández-Estevan, L.; Fernanda Solá-Ruiz, M.; Marco-Pitarch, R.; García-Selva, M.; Zubizarreta-Macho, Á.; León-Martínez, R.,
Peri-Implant Behavior of Tissue Level Dental Implants with a Convergent Neck.,
Int. J. Environ. Res. Public Health 2021, 18, 5232, Doi: 10.3390, ijerph18105232
- i. Palombo D., Rahmati M., Vignoletti F., Sanz-Esporrin J., Haugen H. J., Sanz M.,
Hard and soft tissue healing around implants with a modified implant neck configuration: An experimental in vivo preclinical investigation,
Clin Oral Impl Res. 2021;00:1-15.
- j. Morón-Conejo B, Sanz-Sánchez I, Salido MP, Martínez-Rus F, Pradies G,
The effect of a convergent transmucosal neck on soft tissues and radiographic outcomes: a 1-year follow-up randomized controlled trial,
Clin Oral Investig 2023 Feb 7. doi: 10.1007/s00784-023-04892-9.
- k. Mandillo-Alonso V, Cascos Sanchez R, Antonaya-Martin JL, Laguna-Martos M,
Evaluation of peri-implant soft and hard tissues behavior in screw-retained crowns by the biologically oriented preparation technique: Ambispective longitudinal analytical study,
J Clin Exp Dent. 2022 Jan; 14(1): e64-e71, doi: 10,4317/jced,58924
- l. Mandillo-Alonso V, Cascos Sanchez R, Antonaya-Martin JL, Laguna-Martos M,
Soft tissue thickness evaluation in screw-retained crowns by the biologically oriented preparation technique,
J Clin Exp Dent 2021 Dec 1;13(12): e1209-e1215, doi: 10.4317/jced.58952



rev. 11-25



Sweden & Martina S.p.A.
Via Veneto, 10
35020 Due Carrare (PD), Italy
Tel. +39.049.9124300
info@sweden-martina.com
www.sweden-martina.com
www.prama.sweden-martina.com

Sweden & Martina Ltd - United Kingdom
info.uk@sweden-martina.com
Sweden & Martina Inc. - Distributor for U.S.
info.us@sweden-martina.com

Sweden & Martina Mediterranea S.L. - España
info.es@sweden-martina.com
Sweden & Martina Lda - Portugal
info.pt@sweden-martina.com
Sweden Martina Romania srl - România
info.ro@sweden-martina.com

Gli impianti, le componenti protesiche e gli strumenti chirurgici presenti nella pubblicazione sono Dispositivi Medici e sono fabbricati da Sweden & Martina S.p.A., ad eccezione di:

- Locator Abutment e relative componenti sono dispositivi medici fabbricati da Zest Anchors, Inc., 2875 Loker Avenue East, Carlsbad, CA 92010, USA. Locator è un marchio registrato di Zest Anchors, Inc.
- Pilastrì Dynamic Abutment, Interfase Dinamica e relative componenti sono dispositivi medici fabbricati da Talladium España S.L., Avenida Blondel, 54 3°, 25002 Lleida, Spagna. Dynamic Abutment e Interfase Dinamica sono marchi registrati da Talladium.
- Chiave dinamometrica con leva di controllo TWL e relativo adattatore sono dispositivi medici fabbricati da Elos Medtch Pinol A/S, Engvej 33, 3330 Gorlose, Danimarca.

Gli articoli presenti sono conformi alle norme ISO 9001 e ISO 13485 e sono registrati con marchio CE in accordo con il Regolamento (UE) Dispositivi Medici n.2017/745. Lo stabilimento Sweden & Martina produce Dispositivi Medici in accordo alle cGMP vigenti in USA e in altri paesi del mondo.



Alcuni prodotti potrebbero non essere disponibili in tutti i mercati.

Tutti i marchi presenti nella pubblicazione sono proprietà di Sweden & Martina, con eccezione dei prodotti per i quali è diversamente indicato. Questi prodotti sono destinati agli studi medici e ai laboratori, la loro vendita non è rivolta al paziente.

È vietato rivendere, duplicare o divulgare i prodotti contenuti nella presente pubblicazione senza il consenso scritto di Sweden & Martina S.p.A.

Per ulteriori informazioni sui prodotti, incluse indicazioni, controindicazioni, avvertenze, precauzioni e potenziali effetti collaterali, si faccia riferimento al sito web di Sweden & Martina S.p.A.

I contenuti sono aggiornati al momento della pubblicazione. Contattare l'azienda Sweden & Martina per gli aggiornamenti successivi.